

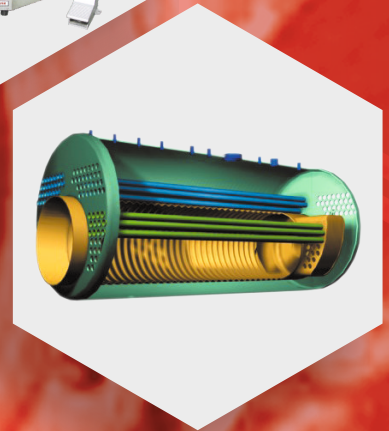

TUBE TOOLS

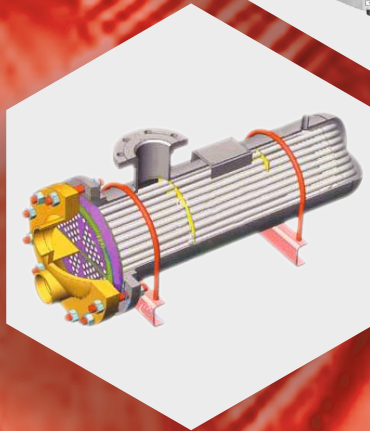

Tools for every conceivable need....

www.powermasteramerica.com



TUBE INSTALLATION TOOLS

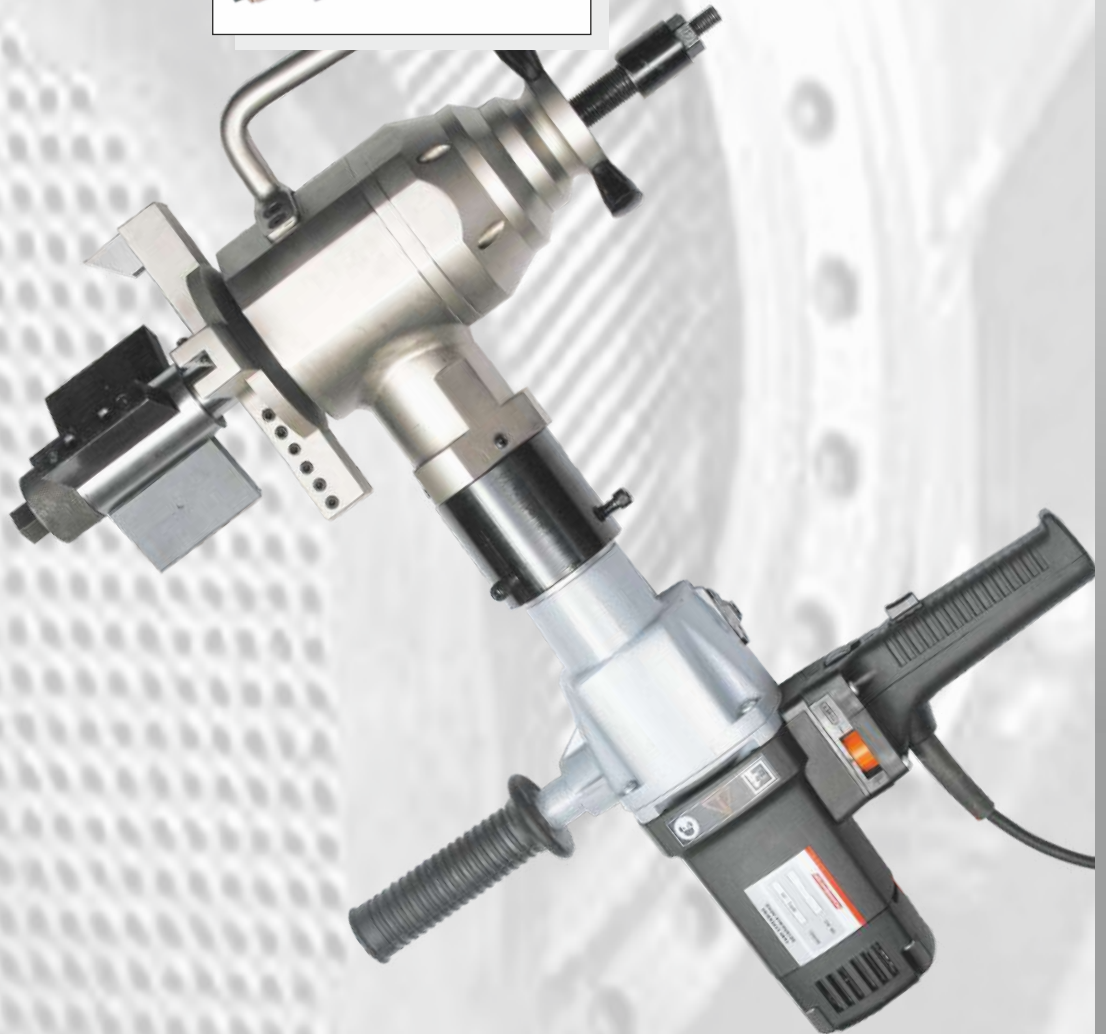

$\frac{3}{8}$ " - $2\frac{1}{2}$ "
O.D.

SERRATING / GROOVING TOOL - 'ST' SERIES

FOR GROOVING IN TUBE SHEETS



TOOL BITS



1/8" x 3/8" x 1/8"



1/8" x 1/4" x 1/8"

Features :

- High production tool.
- Ideal for use where 1 tool is needed per bore.
- One piece cryogenically treated tool bit ensures maximum life.
- Tool is ideally suited for CNC applications on account of 1 piece mandrel construction and short design.

Tube O.D.		Tool Model No.	Spare Tool Bits		
mm	inch		1/8" x 3/8" x 1/8" Spacing	1/8" x 1/4" x 1/8" Spacing	Special Spacing
9.53	3/8	ST-375-970	ST-3703	ST-3703-S	ST-3703-SPEC
12.70	1/2	ST-500-1270	ST-5003	ST-5003-S	ST-5003-SPEC
15.87	5/8	ST-625-1588	ST-6203	ST-6203-S	ST-6203-SPEC
19.05	3/4	ST-750-1900	ST-7503	ST-7503-S	ST-7503-SPEC
22.22	7/8	ST-875-2220	ST-7503	ST-7503-S	ST-7503-SPEC
25.40	1	ST-1000-2540	ST-7503	ST-7503-S	ST-7503-SPEC
31.75	1.1/4	ST-1250-3175	ST-7503	ST-7503-S	ST-7503-SPEC
38.10	1.1/2	ST-1500-3810	ST-7503	ST-7503-S	ST-7503-SPEC
50.80	2	ST-2000-5080	ST-7503	ST-7503-S	ST-7503-SPEC
63.50	2.1/2	ST-2500-6350	ST-7503	ST-7503-S	ST-7503-SPEC

Note : Serrating Tools are available for MM bore sizes also. Please enquire.
Refer to operation manual for spare parts list and detailed features.

$\frac{3}{8}$ " - 4"
O.D.

SERRATING / GROOVING TOOL - 'NW' SERIES



CIRCULAR FORM CUTTER



TOOL BIT HOLDER WITH TOOLBIT

Features :

- Changing of pilot nose and cutter allows one tool to cover a range of hole diameters.
- Simple to change cutter for different groove shapes.
- Location and depth of cut easy to adjust.
- Only light pressure required to cut precision grooves.
- Ready to fit CNC drill machines, lathes and boring machines.
- The life of the cutter extendable by re-sharpening.

Bore Range		Tool Model No.	Pilot Nose Model No.	Circular Form Cutter Model No.	Tool Bit Holder Model No.	Spare Tool Bit Model No.
mm	inch					
9 - 32	3/8 - 1.1/4	1 NW - 2 MT	1 NW - PN	1 NW - CF	1 NW - TBH	1 NW - TB
16 - 45	5/8 - 1.3/4	3 NW - 3 MT	3 NW - PN	3 NW - CF	3 NW - TBH	3 NW - TB
19 - 48	3/4 - 1.7/8	4 NW - 4 MT	4 NW - PN	4 NW - CF	4 NW - TBH	4 NW - TB
38 - 102	1.1/2 - 4	6 NW - 5 MT	6 NW - PN	6 NW - CF	6 NW - TBH	6 NW - TB

Note : Specify whether you need Circular Form Cutter (one piece HSS construction) or Tool Bit Holder with Tool Bit, when ordering.
Refer to operation manual for detailed spare parts list.

SERRATING / GROOVING TOOL - 'SGT' SERIES

$\frac{3}{8}$ " - 3"
O.D.



TOOL BIT

Features :

- Only light pressure required to cut precision grooves inside holes or cylinders.
- Location and depth of groove easy to adjust.
- Simple to change cutter for different groove shapes.
- Changing of bushing and cutter allows one tool to cover a range of hole diameters.
- The life of the cutter extendable by re-sharpening.

Bore Range		Tool Model No.	Pilot Nose / Bushing Model No.	Tool Bits Model No.
mm	inch			
10 - 13	0.40 - 0.51	SGT-102	SGT-102-PN	SGT-102-TB
12.7 - 16	0.50 - 0.63	SGT-122	SGT-122-PN	SGT-122-TB
16 - 20	0.63 - 0.79	SGT-162	SGT-162-PN	SGT-162-TB
19 - 32	0.75 - 1.26	SGT-193	SGT-193-PN	SGT-193-TB
30 - 52	1.18 - 2.05	SGT-303	SGT-303-PN	SGT-303-TB
50 - 78	1.97 - 3.07	SGT-504	SGT-504-PN	SGT-504-TB

Note : Ask for catalog number CTG-100 for spare parts list, operating instructions and detailed features.

PLEASE SUPPLY FOLLOWING INFORMATION WHEN ORDERING GROOVING TOOLS OR SPARE CUTTERS.

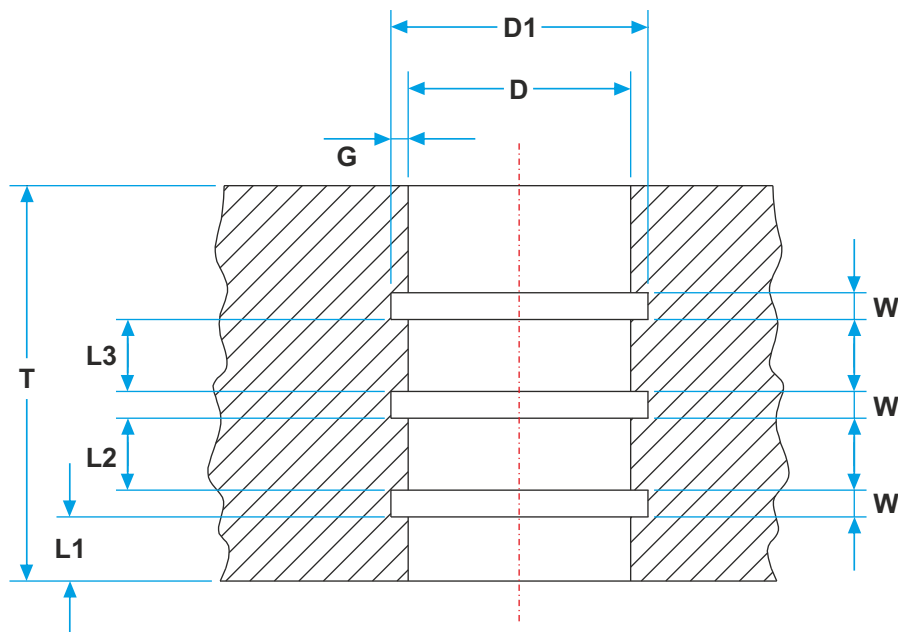

A)	Bore Dia after reaming with Tolerances	D
B)	Tube Plate Thickness	T
C)	Distance of First Groove	L1
D)	Total Number of Grooves	N
E)	Spacing of Grooves	L2, L3
F)	Groove Width	W
G)	Diameter of Grooves	D1
H)	Groove undercut Depth	G

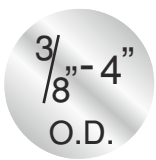

TUBE SHEET HOLE REAMER

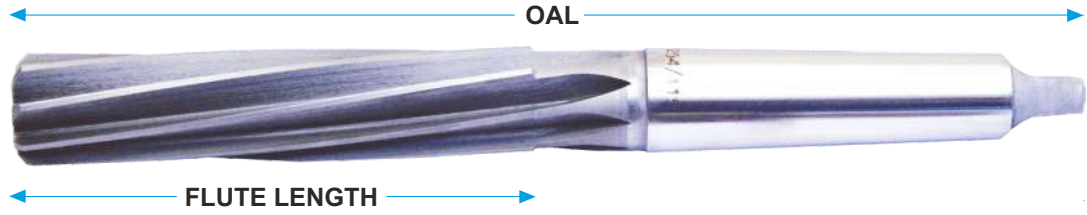

Features :

- High speed steel, cryogenically treated & coated with Titanium Nitride for long life.
- Ideal for heat exchanger and condenser tube sheet reaming.
- Reamers available in MM sizes also.
- For larger diameters, please enquire.

Tube O.D.		Reamer Size to "TEMA" Specification		Model No.	Flute Length		OAL		Shank: Morse Taper #
mm	inch	mm	inch		mm	inch	mm	inch	
9.53	3/8	9.65	.380	RM-095/66	66	2.60	146	5.70	1
				RM-095/101	101	3.97	181	7.12	
				RM-095/152	152	5.98	232	9.13	
12.70	1/2	12.83	.505	RM-127/76	76	2.99	156	6.14	1
				RM-127/101	101	3.97	181	7.12	
				RM-127/152	152	5.98	232	9.13	
15.87	5/8	16.03	.631	RM-158/87	87	3.42	187	7.36	2
				RM-158/152	152	5.98	252	9.92	
				RM-158/203	203	7.99	303	11.93	
16.00	-	16.16	.636	RM-160/87	87	3.42	187	7.36	2
				RM-160/152	152	5.98	252	9.92	
				RM-160/203	203	7.99	303	11.93	
19.05	3/4	19.25	.758	RM-190/100	100	3.90	200	7.87	2
				RM-190/152	152	5.98	252	9.92	
				RM-190/203	203	7.99	303	11.93	
20.00	-	20.20	.795	RM-200/100	100	3.90	200	7.87	2
				RM-200/152	152	5.98	252	9.92	
				RM-200/203	203	7.99	303	11.93	
22.00	-	22.22	.875	RM-220/107	107	4.21	207	8.15	2
				RM-220/152	152	5.98	252	9.92	
				RM-220/203	203	7.99	303	11.93	
22.22	7/8	22.42	.883	RM-222/107	107	4.21	207	8.15	2
				RM-222/152	152	5.98	252	9.92	
				RM-222/203	203	7.99	303	11.93	
25.00	-	25.25	.994	RM-250/115	115	4.53	242	9.53	3
				RM-250/203	203	7.99	330	12.99	
				RM-250/254	254	10.00	381	15.00	
25.40	1	25.65	1.010	RM-254/115	115	4.53	242	9.53	3
				RM-254/203	203	7.99	330	12.99	
				RM-254/254	254	10.00	381	15.00	
28.57	1.1/8	28.86	1.136	RM-285/124	124	4.88	251	9.88	3
				RM-285/203	203	7.99	330	12.99	
				RM-285/254	254	10.00	381	15.00	
31.75	1.1/4	32.07	1.262	RM-317/133	133	5.23	293	11.53	4
				RM-317/203	203	7.99	363	14.29	
				RM-317/254	254	10.00	414	16.30	

TUBE END FACER - 'TEF' SERIES

3/8" - 2 1/2"
O.D.



TOOL BIT



NON-FERROUS

TOOL BIT



STAINLESS

Features :

- Tool bits coated with Titanium Nitride to give 3 times the life of conventional tool bits.
- Ideal for quick facing of projecting tube ends in heat exchangers, condensers and boilers.
- One size of tool is suitable for use on multiple tube thicknesses by interchanging pilot. (TEF-375 is the exception with the tool suitable for one tube ID only).
- Each tool is supplied with a set of multiple pilots to cover all tube thicknesses.
- Tube end facers for MM sizes of tubes also available. Please enquire.

Tube O.D.		Tube Thk. bwg	Model No.	Spare Tool Bits	
mm	inch			Non-Ferrous or Carbon Steel Tubes Model No.	Stainless Steel Tubes Model No.
9.53	3/8	16-22	TEF-375	TEF-376	TEF-376 SS
12.70	1/2	15-20	TEF-500	TEF-506	TEF-506 SS
15.87	5/8	14-18	TEF-625	TEF-626	TEF-626 SS
19.05	3/4	10-18	TEF-750	TEF-756	TEF-756 SS
22.22	7/8	13-18	TEF-875	TEF-876	TEF-876 SS
25.40	1	11-18	TEF-1000	TEF-1006	TEF-1006 SS
28.57	1.1/8	11-18	TEF-1125	TEF-1126	TEF-1126 SS
31.75	1.1/4	11-18	TEF-1250	TEF-1256	TEF-1256 SS
34.92	1.3/8	11-18	TEF-1375	TEF-1376	TEF-1376 SS
38.10	1.1/2	11-18	TEF-1500	TEF-1506	TEF-1506 SS
41.27	1.5/8	11-18	TEF-1625	TEF-1626	TEF-1626 SS
44.45	1.3/4	11-18	TEF-1750	TEF-1756	TEF-1756 SS
47.62	1.7/8	11-18	TEF-1875	TEF-1876	TEF-1876 SS
50.80	2	11-18	TEF-2000	TEF-2006	TEF-2006 SS
57.15	2.1/4	11-18	TEF-2250	TEF-2256	TEF-2256 SS
63.50	2.1/2	11-18	TEF-2500	TEF-2506	TEF-2506 SS

TUBE END FACER - 'FB' SERIES



TOOL BIT

Features :

- High speed production tool.
- Titanium Nitride coated tool bit can be reversed and used. Doubles tool bit life.

Tube O.D.		Tube Thk. bwg	Model No.	Spare Tool Bits	
mm	inch			Non-Ferrous or Carbon Steel Tubes Model No.	Stainless Steel Tubes Model No.
9.53	3/8	16-22	FB-375	FB-376	FB-376 SS
12.70	1/2	15-20	FB-500	FB-506	FB-506 SS
15.87	5/8	14-18	FB-625	FB-626	FB-626 SS
19.05	3/4	10-18	FB-750	FB-756	FB-756 SS
22.22	7/8	13-18	FB-875	FB-876	FB-876 SS
25.40	1	11-18	FB-1000	FB-1006	FB-1006 SS
28.57	1.1/8	11-18	FB-1125	FB-1126	FB-1126 SS
31.75	1.1/4	11-18	FB-1250	FB-1256	FB-1256 SS
34.92	1.3/8	11-18	FB-1375	FB-1376	FB-1376 SS
38.10	1.1/2	11-18	FB-1500	FB-1506	FB-1506 SS
41.27	1.5/8	11-18	FB-1625	FB-1626	FB-1626 SS
44.45	1.3/4	11-18	FB-1750	FB-1756	FB-1756 SS
47.62	1.7/8	11-18	FB-1875	FB-1876	FB-1876 SS
50.80	2	11-18	FB-2000	FB-2006	FB-2006 SS
57.15	2.1/4	11-18	FB-2250	FB-2256	FB-2256 SS
63.50	2.1/2	11-18	FB-2500	FB-2506	FB-2506 SS

TUBE END FACER - 'FC' SERIES / WELD REMOVAL TOOL

Tube O.D.		Facer Fitted With 3 Tool Bits Model No.	Spare Tool Bits Model No.
mm	inch		
38.10	1.1/2	FC-1500	FC-1500-TB
41.27	1.5/8	FC-1625	FC-1625-TB
44.45	1.3/4	FC-1750	FC-1750-TB
47.62	1.7/8	FC-1875	FC-1875-TB
50.80	2	FC-2000	FC-2000-TB
57.15	2.1/4	FC-2250	FC-2250-TB
63.50	2.1/2	FC-2500	FC-2500-TB
69.85	2.3/4	FC-2750	FC-2750-TB
76.20	3	FC-3000	FC-3000-TB
82.55	3.1/4	FC-3250	FC-3250-TB
88.90	3.1/2	FC-3500	FC-3500-TB
95.25	3.3/4	FC-3750	FC-3750-TB
101.6	4	FC-4000	FC-4000-TB



Features :

- Tool uses 3 cutting blades which can be configured for tube end facing or weld removal as a step in the removal of welded tubes from the tube sheet.
- Tool fitted with MT shank for use with standard air or electric drills.
- Cutting blades are Titanium Nitride coated to give 3 times the life of conventional cutting blades.
- Tools available for MM sizes of tubes also. Please enquire.
- Ideally suited for work on larger diameter boiler tubes.

FLARING TOOL

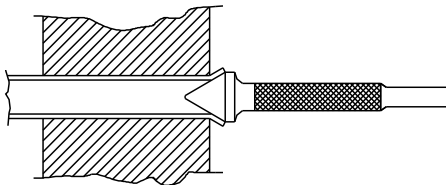

Tube O.D.		Tube Thk. bwg.	Model No.
mm	inch		
12.70	1/2	16-22	FT-1
15.87	5/8	14-15	FT-2
		16-22	FT-3
19.05	3/4	14-15	FT-4
		16-22	FT-5
22.22	7/8	14-15	FT-6
		16-22	FT-7
25.40	1	12-15	FT-8
		16-22	FT-9
28.57	1.1/8	12-15	FT-10
		16-22	FT-11
31.75	1.1/4	8-14	FT-12
		15-22	FT-13
34.92	1.3/8	8-14	FT-14
		15-22	FT-15
38.10	1.1/2	8-14	FT-16
		15-22	FT-17

Note : Fitted with Type 1 round shank for use with standard pneumatic chipping hammer. Other shanks on request.

TUBE SHEET HOLE RADIUS CUTTER

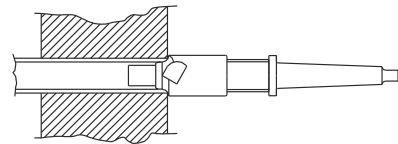

- High speed steel tool used in preparing tube sheets to suit the flaring or beading of tube ends outside of or flush with the tube sheet.
- MM sizes and cutters with other radii are also available. Please enquire.

Tube O.D.		Model No.	Tool Radius		Morse Taper
mm	inch		mm	inch	
12.70	1/2	20338	3.2	1/8	2
15.87	5/8	20224	4.0	5/32	2
19.05	3/4	20225	4.8	3/16	2
22.22	7/8	20226	4.8	3/16	2
25.40	1	20227	4.8	3/16	2
28.57	1.1/8	40512	6.4	1/4	2
31.75	1.1/4	21395	6.4	1/4	2

TUBE SHEET HOLE BRUSH

1/2" - 3"
O.D.



- To clean tube sheet bores, prior to tube installation.
- Can be used with any standard pneumatic or electric drill.

Tube O.D.		Model No.
mm	inch	
12.70	1/2	TSHB-1/2
15.87	5/8	TSHB-5/8
19.05	3/4	TSHB-3/4
22.22	7/8	TSHB-7/8
25.40	1	TSHB-1
31.75	1.1/4	TSHB-1.1/4
38.10	1.1/2	TSHB-1.1/2
44.45	1.3/4	TSHB-1.3/4
50.80	2	TSHB-2
57.15	2.1/4	TSHB-2.1/4
63.50	2.1/2	TSHB-2.1/2
69.85	2.3/4	TSHB-2.3/4
76.20	3	TSHB-3

Note : Available in your choice of carbon steel, stainless steel or brass. For other / larger sizes, please enquire.

TUBE GUIDE

1/2" - 3"
O.D.



- To 'pilot' the tubes through the tube sheets and baffle plates during tube insertion.

Tube O.D.		Tube Thk. bwg.	Model No.	Tube O.D.		Tube Thk. bwg.	Model No.
mm	inch			mm	inch		
12.70	1/2	16-18	PTG-1	31.75	1.1/4	10-13	PTG-15
		19-20	PTG-2			14-20	PTG-16
		21-23	PTG-2.5			8-9	PTG-17
15.87	5/8	12-13	PTG-3	34.92	1.3/8	10-13	PTG-18
		14-16	PTG-4			14-20	PTG-19
		17-20	PTG-5			8-9	PTG-20
		22-24	PTG-5.5			10-13	PTG-21
19.05	3/4	10-12	PTG-6	38.10	1.1/2	14-20	PTG-22
		13-16	PTG-7			8-10	PTG-23
		17-20	PTG-8			11-13	PTG-24
		22-24	PTG-8.5			14-18	PTG-25
22.22	7/8	10-12	PTG-9	50.80	2	10-13	PTG-26
		13-16	PTG-10			14-18	PTG-27
		17-20	PTG-11				
		21-22	PTG-11.5				
25.40	1	8-9	PTG-12.5	63.50	2.1/2		
		10-12	PTG-12				
		13-16	PTG-13				
		17-20	PTG-14				
		21-23	PTG-14.5				
31.75	1.1/4	10-13	PTG-15				
		14-20	PTG-16				

Note : For other / larger sizes, please enquire.

TUBE LEAK DETECTOR KIT

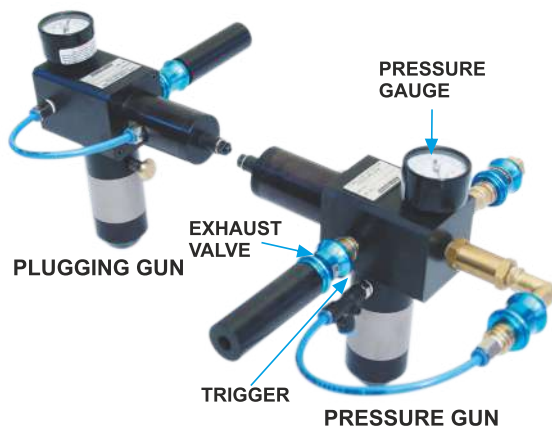

Features :

- Simple, Quick and Reliable tube testing. Test 7 to 8 tubes per minute.
- Interchangeable seal sets : Allows testing of tubes from 7.75 mm to 30.63 mm ID with easy to replace accessories.
- Each Tube Testing Gun weighs less than 1.3 kg.
- Air supply : Uses standard plant air supplies from 70 psi to 100 psi (4.7 to 6.8 bar).
- Silent during use. Ergonomic design makes testing effortless.
- Each Kit packed in compact and handy case.

SEQUENCE OF OPERATION

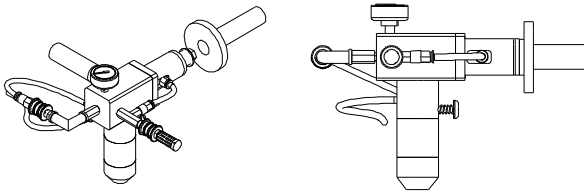
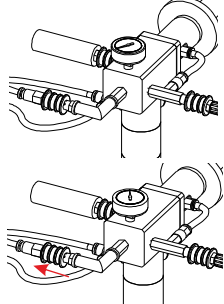
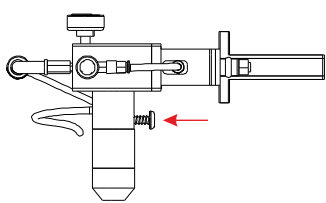
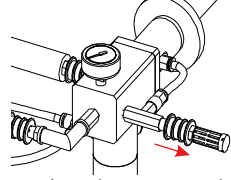
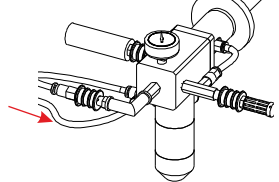
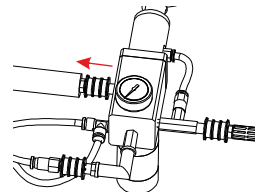
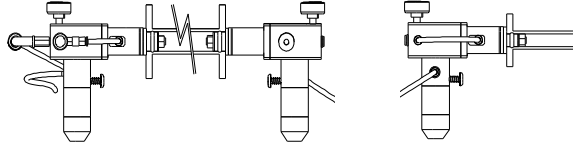
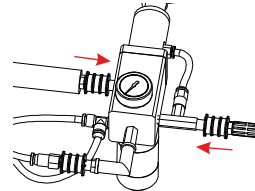
 <p>A) Insert tube seal of Pressure gun into tube to be tested. The cover must rest firmly on tube end surface. Tube seal is in COLLAPSED state when inserting.</p>	 <p>E) GRADUALLY pressurise tube by sliding tube pressurising valve to right. Allow tube pressure to build up to 5-6 bar. This is indicated on pressure gauges on both guns. Slide tube pressurising valve from right to left to stop pressurising tube once 5-6 bar pressure is reached in the tube. Monitor pressure gauge for few seconds to find leakage in tube. Pressure drop indicated in pressure gauge indicates a leakage in tube. Stable pressure indication in pressure gauge indicates a healthy non-leaky tube.</p>
 <p>B) Press Trigger of Pressure gun to bulge seal. A proper size seal will grip into tube inner diameter.</p>	 <p>F) After test, first exhaust the tube pressure by sliding left to right tube exhaust valve on Pressure gun. NOTE : DO NOT slide the seal exhaust valve before de pressurising the tube. The gun will be thrown out if the seal collapses while air pressure still exists in the tube.</p>
 <p>C) Operator holding the Pressure gun can blow air through the tube to help the Plugging gun operator identify the tube being tested. Sliding pressurising valve from left to right as shown in the picture blows air.</p>	 <p>G) Withdraw both the guns after collapsing the tube seal using tube seal exhaust valve.</p>
 <p>PRESSURE GUN PLUGGING GUN PLUGGING GUN</p> <p>D) Once Plugging gun operator identifies tube, stop blowing air to allow Plugging gun to be inserted into identified tube. Press Trigger of Plugging gun to expand Plugging gun seal. Press Trigger of Pressure gun to expand seal.</p>	 <p>H) Close tube seal exhaust valve in both guns by sliding back from left to right. Close tube exhaust valve by sliding right to left. The guns are now prepared to test the next tube.</p>

TUBE LEAK DETECTOR KIT SPECIFICATIONS

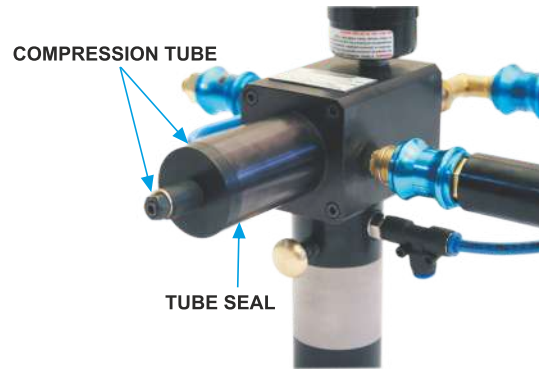

Tube Size		Tube ID Range		Tube Seal Part No.	Tube Seal Diameter		Compression Tube Part No.
O.D.	bwg	mm	inch		mm	inch	
5/8"	9	8.37	.330	TLD-300N	7.5	.295	TLD-15-125
	10-13	9.07 - 11.05	.357 - .435	TLD-370N	9	.354	
	14-15	11.67 - 12.23	.459 - .481	TLD-450N	11.6	.457	
	16-17	12.57 - 12.93	.495 - .509	TLD-470N	12.2	.480	TLD-15-312
	18-19	13.39 - 13.75	.527 - .541	TLD-490N	13.3	.523	
	20-24	14.11 - 14.77	.555 - .581	TLD-530N	13.8	.543	
3/4"	9	11.55	.455	TLD-430N	10.8	.425	TLD-15-312
	10 - 11	12.25 - 12.95	.482 - .510	TLD-450N	11.6	.457	TLD-15-125
	12 - 13	13.53 - 14.23	.532 - .560	TLD-490N	13.3	.523	TLD-15-312
	14 - 15	14.85 - 15.41	.584 - .606	TLD-530N	13.8	.543	
	16 - 17	15.75 - 16.11	.620 - .634	TLD-570N	15.4	.606	
		18 - 19	16.57 - 16.93	.652 - .666	TLD-610N	16.5	.649
	20 - 24	17.29 - 17.95	.680 - .706	TLD-650N	17.0	.669	TLD-15-405
7/8"	8-9	13.84 - 14.72	.544 - .579	TLD-530N	13.8	.543	TLD-15-312
	10-11	15.42 - 16.12	.607 - .635	TLD-570N	15.4	.606	
	12-13	16.7 - 17.4	.657 - .685	TLD-610N	16.5	.649	
	14-15	18.02 - 18.58	.709 - .731	TLD-690N	18	.708	TLD-15-405
	16-17	18.92 - 19.28	.745 - .759	TLD-730N	18.6	.732	
		18-19	19.74 - 20.1	.777 - .791	TLD-740N	19.7	.775
	20-24	20.46 - 21.12	.805 - .831	TLD-790N	20.1	.791	
1"	8-9	17.02 - 17.9	.670 - .704	TLD-650N	17	.669	TLD-15-405
	10-11	18.6 - 19.3	.732 - .760	TLD-690N	18	.708	TLD-15-312
	12-13	19.88 - 20.58	.782 - .810	TLD-740N	19.7	.775	
	14-15	21.2 - 21.76	.834 - .856	TLD-790N	20.1	.791	
	16-17	22.1 - 22.46	.870 - .884	TLD-840N	21.7	.854	TLD-15-405
	18-19	22.92 - 23.28	.902 - .916	TLD-870N	22.9	.901	
	20-24	23.64 - 24.3	.930 - .956	TLD-890N	23.3	.917	
1.1/8"	8-9	20.19 - 21.07	.795 - .829	TLD-790N	20.1	.791	TLD-15-312
	10-11	21.77 - 22.47	.857 - .884	TLD-840N	21.7	.854	TLD-15-405
	12-13	23.05 - 23.75	.907 - .935	TLD-870N	22.9	.901	
	14-15	24.37 - 24.93	.959 - .981	TLD-890N	23.3	.917	
	16-17	25.27 - 25.63	.994 - 1.009	TLD-980N	25.2	.992	TLD-15-405
	18-19	26.09 - 26.45	1.027 - 1.041	TLD-990N	26.0	1.024	
	20-24	26.81 - 27.47	1.055 - 1.081	TLD-1040N	26.8	1.055	
1.1/4"	8-11	23.37 - 25.65	.920 - 1.01	TLD-890N	23.3	.917	TLD-15-405
	12-13	26.23 - 26.93	1.032 - 1.060	TLD-990N	26.0	1.024	
	14-17	27.55 - 28.81	1.084 - 1.134	TLD-1090N	27.5	1.082	
	18-24	29.27 - 30.65	1.152 - 1.206	TLD-1100N	29.2	1.149	

TUBE TO TUBE SHEET JOINT TESTING KIT

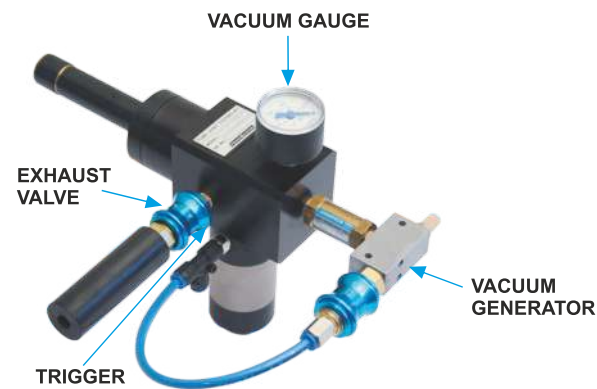

Features :

- Simple, Quick and Reliable tube joint testing. Test 10 tube joints per minute.
- Interchangeable seal sets : Allows testing of tube joints from 7.75 mm to 30.63 mm ID with easy to replace accessories.
- Joint Testing Gun weights less than 1.5 kg.
- Air supply : Uses standard plant air supplies from 70 psi to 100 psi (4.7 to 6.8 bar).
- Silent during use. Ergonomic design makes testing effortless.
- Each Kit packed in compact and handy case.

SEQUENCE OF OPERATION

<p>A) Close exhaust valve by sliding to extreme right</p>	<p>D) Slide vacuum valve to right to start generating vacuum. Gauge will indicate vacuum level.</p>
<p>B) Insert manifold till square o-ring firmly sits on tube</p>	<p>E) Close vacuum slide valve by shifting to left. This will stop vacuum generation. Observe vacuum gauge. Vacuum level falls if the joint is leaking.</p>
<p>C)</p>	<p>F) After testing the joint release the tube seal by sliding the exhaust to the left. The Joint Testing Kit can be withdrawn after the tube seal collapses.</p>

TUBE TO TUBE SHEET JOINT TESTING KIT SPECIFICATIONS

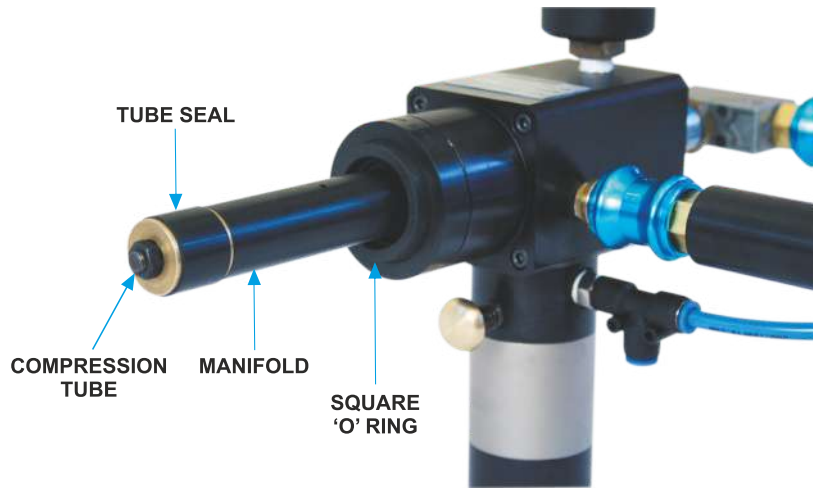

Tube Size		Tube ID Range		Tube Seal Part No.	Tube Seal Diameter		Manifold with Square O ring	Compression Tube Part No.	Square O ring
O.D.	bwg	mm	inch		mm	inch			
5/8"	9	8.37	.330	JTK-300N	7.5	.295	JTM-15-125-5/8	JTK-15-125	JTK-16-5/8
	10-13	9.07 - 11.05	.357 - .435	JTK-370N	9	.354			
	14-15	11.67 - 12.23	.459 - .481	JTK-450N	11.6	.457			
	16-17	12.57 - 12.93	.495 - .509	JTK-470N	12.2	.480			
	18-19	13.39 - 13.75	.527 - .541	JTK-490N	13.3	.523			
	20-24	14.11 - 14.77	.555 - .581	JTK-530N	13.8	.543			
3/4"	9	11.55	.455	JTK-430N	10.8	.425	JTM-15-312-3/4-1	JTK-15-312	JTK-16-3/4
	10 - 11	12.25 - 12.95	.482 - .510	JTK-450N	11.6	.457	JTM-15-125-3/4	JTK-15-125	
	12 - 13	13.53 - 14.23	.532 - .560	JTK-490N	13.3	.523	JTM-15-312-3/4-2	JTK-15-312	
	14 - 15	14.85 - 15.41	.584 - .606	JTK-530N	13.8	.543			
	16 - 17	15.75 - 16.11	.620 - .634	JTK-570N	15.4	.606			
	18 - 24	16.57 - 17.95	.652 - .706	JTK-610N	16.5	.649			
7/8"	8-9	13.84 - 14.72	.544 - .579	JTK-530N	13.8	.543	JTM-15-312-7/8-1	JTK-15-312	JTK-16-7/8
	10-11	15.42 - 16.12	.607 - .635	JTK-570N	15.4	.606			
	12-13	16.7 - 17.4	.657 - .685	JTK-610N	16.5	.649			
	14-17	18.02 - 19.28	.709 - .759	JTK-690N	18	.708	JTM-15-312-7/8-2		
	18-19	19.74 - 20.1	.777 - .791	JTK-740N	19.7	.775			
	20-24	20.46 - 21.12	.805 - .831	JTK-790N	20.1	.791			
1"	8-9	17.02 - 17.9	.670 - .704	JTK-610N	16.5	.649	JTM-15-312-1	JTK-15-312	JTK-16-1
	10-11	18.6 - 19.3	.732 - .760	JTK-690N	18	.708			
	12-13	19.88 - 20.58	.782 - .810	JTK-740N	19.7	.775			
	14-15	21.2 - 21.76	.834 - .856	JTK-790N	20.1	.791			
	16-17	22.1 - 22.46	.870 - .884	JTK-840N	21.7	.854	JTM-15-405-1		
	18-19	22.92 - 23.28	.902 - .916	JTK-870N	22.9	.901			
	20-24	23.64 - 24.3	.930 - .956	JTK-890N	23.3	.917			
1.1/8"	8-9	20.19 - 21.07	.795 - .829	JTK-790N	20.1	.791	JTM-15-312-1.1/8	JTK-15-312	JTK-16-1.1/8
	10-11	21.77 - 22.47	.857 - .884	JTK-840N	21.7	.854	JTM-15-405-1.1/8	JTK-15-405	
	12-13	23.05 - 23.75	.907 - .935	JTK-870N	22.9	.901			
	14-15	24.37 - 24.93	.959 - .981	JTK-890N	23.3	.917			
	16-17	25.27 - 25.63	.994 - 1.009	JTK-980N	25.2	.992			
	18-19	26.09 - 26.45	1.027 - 1.041	JTK-990N	26.0	1.024			
	20-24	26.81 - 27.47	1.055 - 1.081	JTK-1040N	26.8	1.055			
1.1/4"	8-11	23.37 - 25.65	.920 - 1.01	JTK-890N	23.3	.917	JTM-15-405-1.1/4	JTK-15-405	JTK-16-1.1/4
	12-13	26.23 - 26.93	1.032 - 1.060	JTK-990N	26.0	1.024			
	14-17	27.55 - 28.81	1.084 - 1.134	JTK-1090N	27.5	1.082			
	18-24	29.27 - 30.65	1.152 - 1.206	JTK-1100N	29.2	1.149			

TUBE / PIPE BEVELLING MACHINES

FM-1625

The FM-1625 is light weight and powerful machine for facing, beveling, and weld preparation. It is compact, easy to handle and quick to setup. It is used for jobs in restricted access areas. Used in shutdown environments on condensers and heat exchangers.

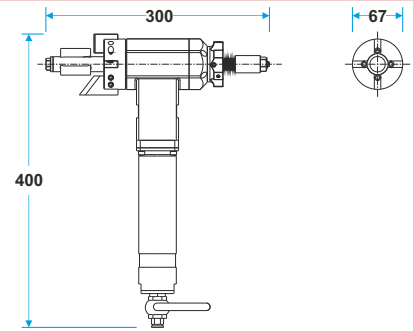

Drive	Pneumatic	Electric
Locking Range (mm)	20 - 42	20 - 42
Ideal Speed (RPM)	400	250
Torque (Nm)	27.5	45.0
Feeding Stroke (mm)	23	23
Pneumatic Power (HP)	0.60	--
Air Consumption (cfm)	16	--
Air Pressure (psi)	90	--
Electric Power (watts)	--	650
Weight (kg)	5.5	5.5

CUTTING BITS

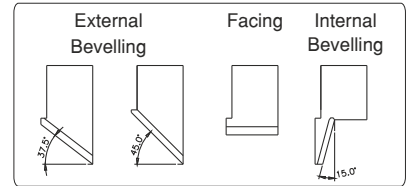

FM-3000

The FM-3000 the most popular and powerful machine. Used during maintenance and new boiler manufacturing. Quick interchangeability of locking jaws to suit wide range of dia meters. Modular and ergonomic design.

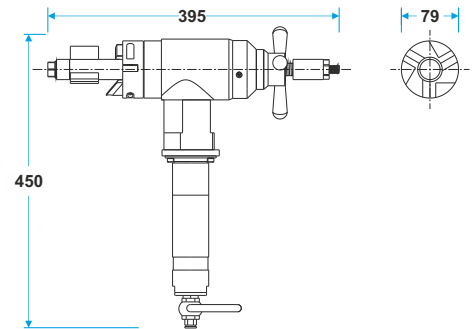

Drive	Pneumatic	Electric
Locking Range (mm)	28 - 76	28 - 76
Ideal Speed (RPM)	110	140
Torque (Nm)	84	138
Feeding Stroke (mm)	40	40
Pneumatic Power (HP)	0.83	--
Air Consumption (cfm)	42	--
Air Pressure (psi)	90	--
Electric Power (watts)	--	595
Weight (kg)	9.5	11.0

CUTTING BITS

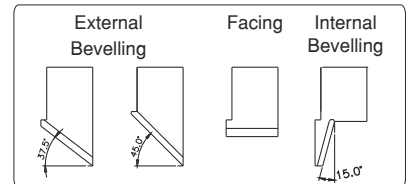

FM-4500

The FM-4500 is a heavy duty machine designed to bevel, face and prepare weld edges for heavy wall thickness tubes. Modular and ergonomic design.

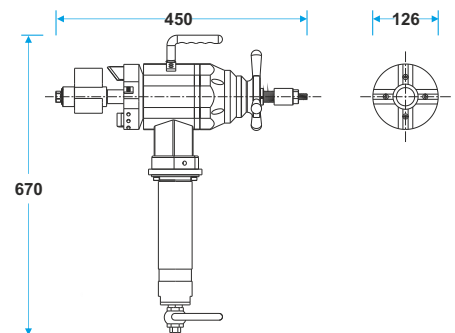

Drive	Pneumatic	Electric
Locking Range (mm)	39 - 104	39 - 104
Ideal Speed (RPM)	60	60
Torque (Nm)	220	240
Feeding Stroke (mm)	40	40
Pneumatic Power (HP)	1.3	--
Air Consumption (cfm)	40	--
Air Pressure (psi)	90	--
Electric Power (watts)	--	1800
Weight (kg)	21.0	23.0

CUTTING BITS

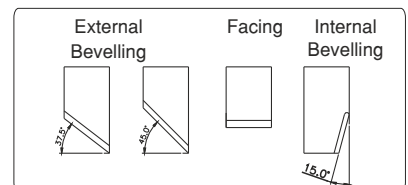

TUBE / PIPE BEVELLING MACHINES

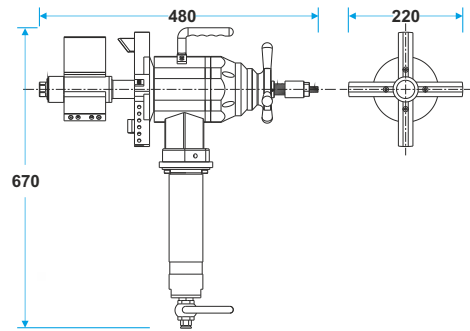
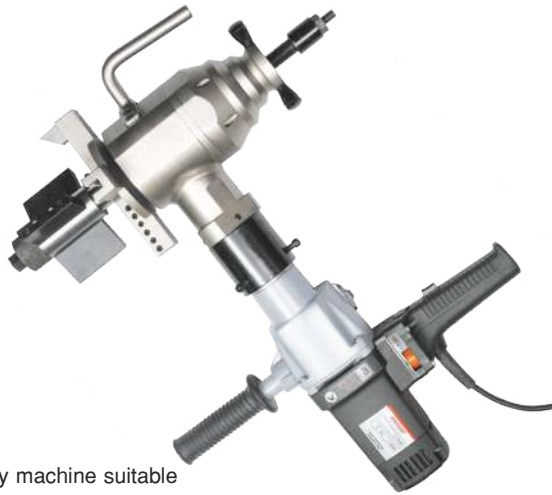

FM-8000

The FM-8000 is a heavy duty machine suitable for use on a wide range of tube I.D's. Designed to bevel, face and produce weld preps on any thickness pipe or tube. Modular and ergonomic design with high torque to suit in toughest working condition.

Drive	Pneumatic	Electric
Locking Range (mm)	51 - 203	51 - 203
Ideal Speed (RPM)	40	40
Torque (NM)	220	240
Feeding Stroke (mm)	40	40
Pneumatic Power (HP)	1.3	--
Air Consumption (cfm)	40	--
Air Pressure (psi)	90	--
Electric Power (watts)	--	1800
Weight (Kg)	26.5	30.0

CUTTING BITS

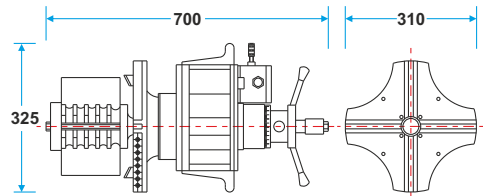
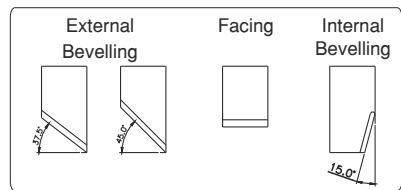

FM-12000

The FM-12000 is a combination of power and range in a light and portable design. Wide range for tube end facing, beveling, counter boring and weld edge preparation. Rugged and balanced machine suitable for all sizes of tube and pipes.

Drive	Pneumatic	Electric
Locking Range (mm)	100 - 306	100 - 306
Ideal Speed (RPM)	35	31
Torque (Nm)	180	230
Feeding Stroke (mm)	50	50
Pneumatic Power (HP)	1.9	--
Air Consumption (cfm)	60	--
Air Pressure (psi)	90	--
Electric Power (watts)	--	1400
Weight (kg)	43.0	44.0

CUTTING BITS

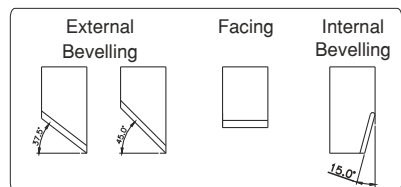

TUBE BUNDLE INSERTER

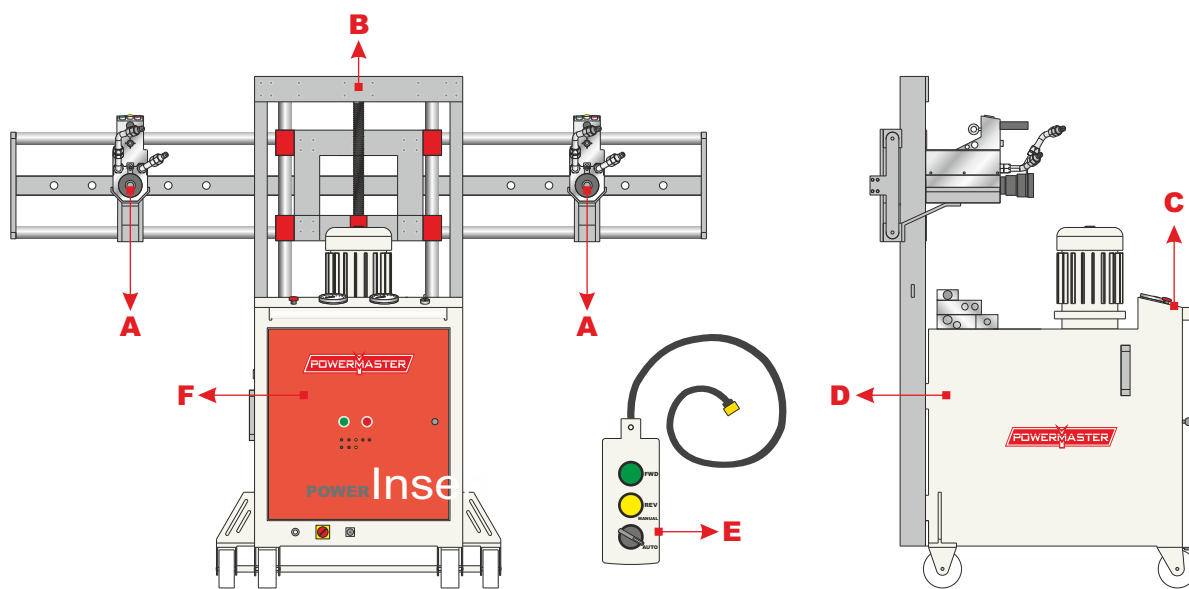

A	Fully Automatic Hydraulic Pistons
B	Biaxial positioning frame with horizontal. Vertical movement.
C	Control Panel
D	Hydraulic Powerpack
E	Remote Control
F	Electrical Cabinet

Features :

- Used for insertion of long & heavy tube bundle inside shell of heat exchanger.
- Insert tube bundle at rate of 3mtrs/min.
- Generates a coaxial force of 60 tons to insert tube bundle into the shell without jolts thereby avoiding damages to shell & bundles.
- Can be easily converted into double headed tube puller for tube extraction.

TECHNICAL SPECIFICATIONS

Model	Pulling Force	Insertion Speed	Maximum Pressure	Power	Volts/phase	Tank Capacity	Weight
	Tons					Liter	
TBI	60	3	300	8	380-50Hz/3	150	800

POWERMASTER AMERICA LLC.

26, Russell Park Road, Syosset, New York 11791.

Phone : +1 516.503.5294

Website: www.powermasteramerica.com Email: sales@powermasteramerica.com