

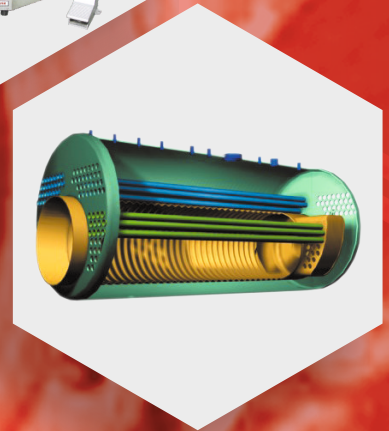

## TUBE TOOLS

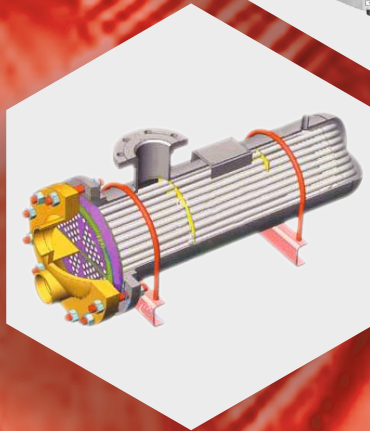

*Tools for every conceivable need....*

[www.powermasteramerica.com](http://www.powermasteramerica.com)



# TUBE REMOVAL TOOLS

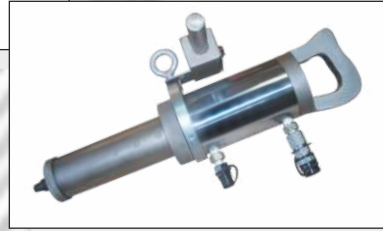

$\frac{3}{8}$ " -  $\frac{1}{4}$ "  
O.D.

# AIR / HYDRAULIC STUB PULLER

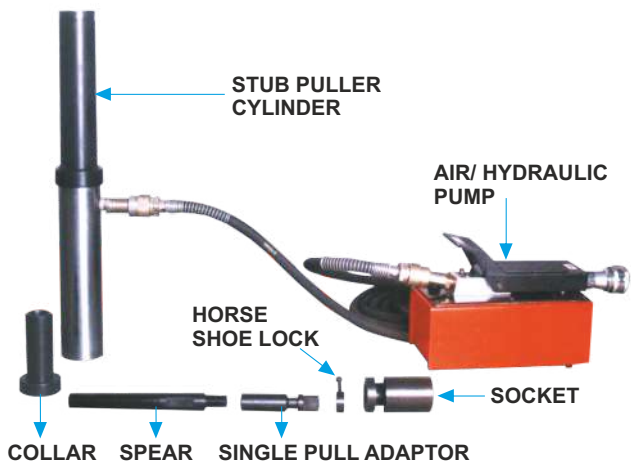

- Features :*
- Improved productivity and better operator control through foot pedal.
  - Extremely compact, durable, lightweight and portable package-useful in confined areas.
  - Makes pulling tubes faster and easier.
  - Quick and easy arrangement to reduce downtime.
  - Safe. Totally air operated for use in explosive environments.

**Air-Powered Hydraulic Stub Puller set consists of :**  
Self Tapping Spear . Air Powered hydraulic Pump with FRL unit.  
Stub Puller cylinder assembly (supplied in 2 models). Carrying case.

## AIR / HYDRAULIC PUMP - MODEL NO. ASP-1008

Length (mm)	264
Width (mm)	135
Height (mm)	205
Weight without oil (kg)	6.6
Hose Length (ft.)	6
Hose I.D. (Inch)	1/4"
Air inlet Port	1/2" BSP
Hydraulic Port	3/8" NPT
Hydraulic Oil	VG ISO 68 Grade
Working Air pressure (bar)	7
Working hydraulic pressure (bar)	700

## STUB PULLER CYLINDER

Model	AHSP-4	AHSP-9
Extraction Load (Ton)	4	9
Recommended Tube Sizes	Up to 3/4" OD	Up to 1.1/4" OD
Overall Dimension (mm) L x Ø	550 x Ø65.0	550 x Ø104.0
Stroke (mm)	150	150
Pulling Speed Secs. / Stroke	15	30
Weight (kg) with accessories	9	18.5



## SPRING BALANCER

Model	Balancing Capacity	Suitable For
SWF-9	5 - 9 kgs	AHSP-4
SWF-22	15 - 22 kgs	AHSP-9

## SELECTION CHART FOR SPARES

Spares	Spare Code	Suitable For
Filter Regulator Lubricator (FRL)	ASP-1001	AHSP-4/AHSP-9
QRC for air inlet	ASP-1006	
QRC WP-700 bar (male)	ASP-1010	
Hydraulic hose	ASP-1011	
QRC WP-700 bar (female)	ASP-1012	
Support Collar -1	ASP-1014a ASP-1014b	
Spear Lock Adapter	ASP-1015a	AHSP-4
	ASP-1015b	AHSP-9
Horse Shoe Lock	ASP-1016a	AHSP-4
	ASP-1016b	AHSP-9
Single Pull Adapter	ASP-1017a	AHSP-4
	ASP-1017b	AHSP-9



## PULLING SPEARS

Model	Tube O.D. inch	Tube thk. bwg	Model	Tube O.D. inch	Tube thk. bwg
SS-0916	3/8	16-17	SS-2212	7/8	12-13
SS-0918	3/8	18-19	SS-2214	7/8	14-15
SS-0920	3/8	20-21	SS-2216	7/8	16-17
SS-0922	3/8	22-23	SS-2218	7/8	18-19
SS-1214	1/2	14-15	SS-2220	7/8	20-21
SS-1216	1/2	16-17	SS-2509	1	9-10
SS-1218	1/2	18-19	SS-2510	1	10-11
SS-1220	1/2	20-21	SS-2512	1	12-13
SS-1222	1/2	22-23	SS-2514	1	14-15
SS-1512	5/8	12-13	SS-2516	1	16-17
SS-1514	5/8	14-15	SS-2518	1	18-19
SS-1518	5/8	18-19	SS-2520	1	20-21
SS-1520	5/8	20-21	SS-3112	1.1/4	12-13
SS-1911	3/4	11-12	SS-3114	1.1/4	14-15
SS-1912	3/4	12-13	SS-3116	1.1/4	16-17
SS-1914	3/4	14-15	SS-3118	1.1/4	18-19
SS-1916	3/4	16-17	SS-3120	1.1/4	20-21
SS-1918	3/4	18-19			
SS-1920	3/4	20-21			

**NOTE :** • Pulling Spears, Single and Double Pull Adaptors, Horse Shoe Locks and Extensions are compatible for use with 'Pine Jenny' type tube pullers.  
• For larger size tube pulling spears, please enquire.

# CONTINUOUS HYDRAULIC TUBE PULLER

3/8" - 4"  
O.D.



## Features :

- Pulling gun communicates with electric powerpack via 9v DC control. This ensures safety and eliminates the need of electrical cord between pump and gun that other manufacturers provide. In pneumatic version communication is via pneumatic control.
- Available with a choice of Electric-TPP System or Pneumatic-PPP System for hazardous, explosive working environments.
- Microprocessor controls on powerpack and gun ensure trouble free life.
- Removes tube without any damage to tube sheet.
- Low setup time and ease of operation.
- High power & High speed automatic cycling, for highest speed of pull available worldwide.
- Auto switchover from low pressure high flow to high pressure low flow on load and again back to low pressure high flow when load is released.
- Automatic slow start feature to minimize risk of breaking tubes and to conserve consumables.
- Compact design of Powerpack and Gun.
- Interchangeable pulling guns with same Powerpack. 15 ton gun for light duty high speed work, 30 ton gun for heavy duty tube pulling and 45 ton gun for tubes upto 3" O.D.
- Pulls up to 3" OD tubes continuously, pulls up to 4" O.D. stub.
- Low maintenance cost and worldwide availability of components.
- Significant saving of time and money over conventional systems.
- Unit is portable with handle and mounted on four wheels for easy handling.
- Unit will pull tubes continuously through the gun effortlessly, needing only one man for operation.

## SEQUENCE OF OPERATION

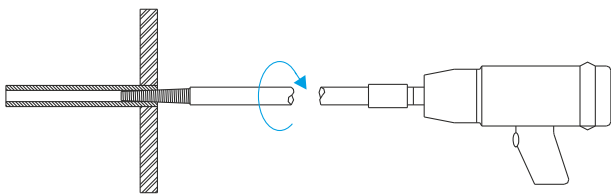

**A)** Thread mandrel into tube with Impact Wrench

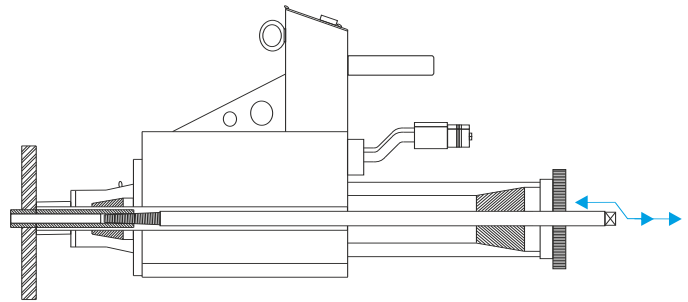

**C)** Switch to Auto Cycle by pressing 'AUTO' button till tube is completely removed. Gun will continue to cycle till one of the other buttons is pressed. When the tube is free, a tool can be inserted into the jaws to enable the tube to be pulled by hand.

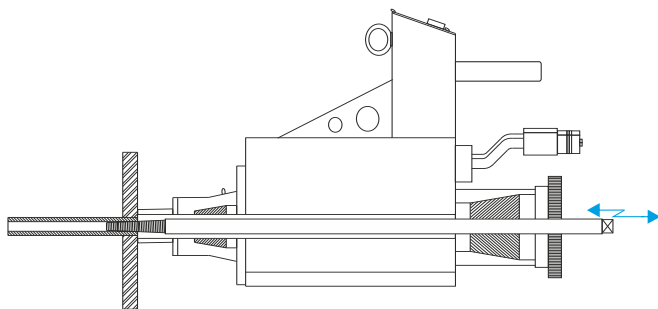

**B)** Mount Pulling Gun onto mandrel. Automatic Slow Start to first break expanded joint.

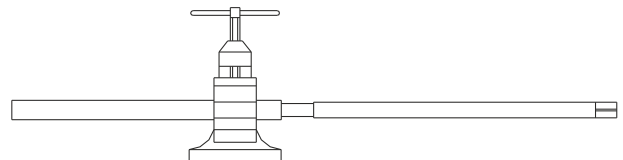

**D)** Unscrew mandrel from pulled tube and proceed to next tube.

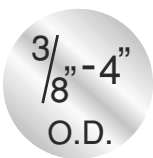

**CONTINUOUS HYDRAULIC TUBE PULLER**



**TPP-50 (Electric) Pump**



**PPP-50 (Pneumatic) Pump**

**TUBE PULLING POWERPACK - SPECIFICATIONS**



Model	Motor	Volts/Phase	Power hp	Oil Tank Capacity ltrs.	Net Wt. kgs.	Dim. mm	Air Supply	Hyd.Hoses Size x Length inch x mtrs.
TPP-50	Siemens	415 / 3	5	90	220	1200 x 750 x 990	-	1/2"x5 & 3/4"x5
TPP-30	Siemens	230 / 1	3	12	42	500 x 410 x 750	-	1/2"x5 & 3/4"x5
PPP-50 (Pneumatic)	Gast	-	9	90	220	1200 x 750 x 990	180CFM AT 7 BAR	1/2"x5 & 3/4"x5

**Note :** Max. Working Pressure 350 Bar  
ALL Powerpacks supplied with 5 mtr. long hydraulic hoses.

**HYDRAULIC TUBE PULLING GUNS (ELECTRIC) - SPECIFICATIONS**



Gun Model	Pulling Capacity tons	Max. Tube O.D. Thru Gun inch	Stub Pulling Capacity inch	Weight		Free Pulling Speed (meter/min) with		
				kgs.	lbs.	TPP-50	TPP-30	PPP-50
HPG-15	15	1	1.1/2	26	57	5.2	1.8	5.6
HPG-30	30	1.1/2	3	38	84	3.0	2.4	3.5
HPG-45	45	3	4	78	172	2.0	2.0	2.3



**HYDRAULIC TUBE PULLING GUNS (PNEUMATIC) - SPECIFICATIONS**



Gun Model	Pulling Capacity tons	Max. Tube O.D. Thru Gun inch	Stub Pulling Capacity inch	Weight		Free Pulling Speed (meter/min) with		
				kgs.	lbs.	TPP-50	TPP-30	PPP-50
AHPG-15	15	1	1.1/2	26	57	5.2	1.8	5.6
AHPG-30	30	1.1/2	3	38	84	3.0	2.4	3.5
AHPG-45	45	3	4	78	172	2.0	2.0	2.3

**Note :** All pulling guns are supplied with Forward, Reverse, and Auto Cycle Switches.

# ACCESSORIES FOR CONTINUOUS TUBE PULLER

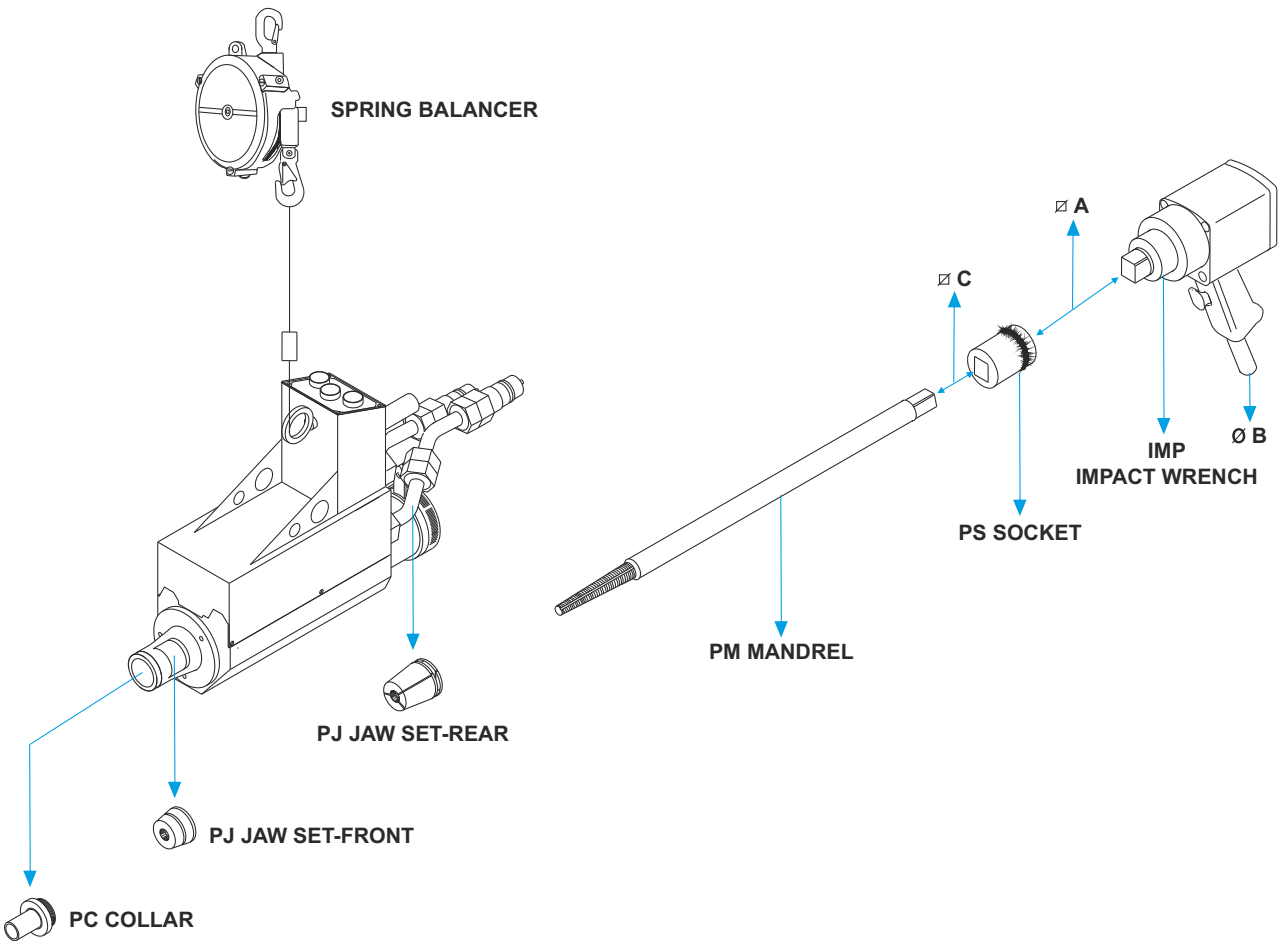

## SPRING BALANCER

- Used to suspend pulling guns for 'feather touch', operation.
- Frees the operator from handling weight of the gun, allowing him to concentrate on the tube pulling operation.

Model	Balancer Range		For Pulling Gun Model	Weight	
	kg	lbs		kgs.	lbs.
SWF-30	20 - 30	44 - 66	HPG-15 / AHPG-15	9.5	21.0
SWF-40	30 - 40	66 - 88	HPG-30 / AHPG-30	10.5	23.1
SWF-85	70 - 85	154 - 187	HPG-45 / AHPG-45	15.0	33.0

## IMP - IMPACT WRENCH

- Used to thread PM mandrels into tube with help of sockets.

Model	Suited For Mandrel Model Numbers	Weight		Ø A	Ø B
		kg	lbs		
IMP-1	PM-7 to PM-37	5.0	11.0	3/4"	3/8"
IMP-2	PM-19 to PM-95/102	10.5	23.0	1"	1/2"

## PS - SOCKET

- Used to connect impact wrench to pulling mandrel.

Model	Ø A	Ø C
PS-1	3/4"	3/8"
PS-2	3/4"	1/2"
PS-3	3/4"	5/8"
PS-4	3/4"	3/4"
PS-5	3/4"	1"
PS-6	1"	3/4"
PS-7	1"	1"
PS-8	1"	1.1/2"

# WORKING CONSUMABLES - CONTINUOUS TUBE PULLER

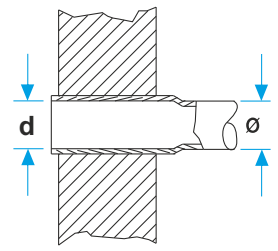
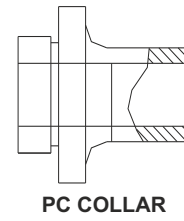
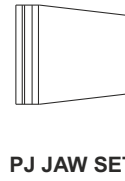
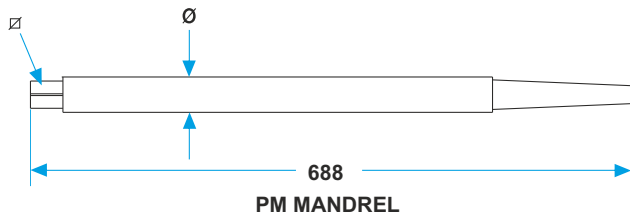

Tube Size		Tube I.D. after Expansion d		Mandrel		Jaw Set			Collar		
Ø	bwg	mm	inch	Model	Square Size	Model For HPG-15	Model For HPG-30	Model For HPG-45	Model For HPG-15	Model For HPG-30	Model For HPG-45
Ø	bwg	mm	inch	PM	Ø	PJ 15	PJ 30	PJ 45	PC 15	PC 30	PC 45
3/8"	17-19	6.5-7.5	0.260-0.295	7	5/16"	1	1		11	11	
	20-24	7.5-8.5	0.295-0.335	8							
1/2"	14-16	8.5-9.5	0.335-0.375	9	3/8"	2	2		15	15	
	17-18	9.5-10.5	0.375-0.415	10							
	19-21	10.5-11.5	0.415-.0.455	11							
	24	11.5-12.5	0.455-0.495	12							
5/8"	16-17	12.5-13.5	0.495-0.535	13 A	1/2"	3	3		18	18	
	19-21	13.5-14.5	0.535-0.570	14 A							
	23-24	14.5-15.5	0.570-0.610	15 A							
3/4"	11	12.5-13.5	0.495-0.535	13	5/8"	4	4		21	21	
	12-13	13.5-14.5	0.535-0.570	14							
	14-15	14.5-15.5	0.570-0.610	15							
	16-17	15.5-16.5	0.610-0.650	16							
	18-20	16.5-17.5	0.650-0.690	17							
	21-24	17.5-18.5	0.690-0.730	18							
7/8"	14	17.5-18.5	0.690-0.730	18 S	5/8"	4/A	4/A		25	25	
	16-17	18.5-19.5	0.730-0.770	19 S							
	18-19	19.5-20.5	0.770-0.810	20 S							
1"	10-11	18.5-19.5	0.730-0.770	19	3/4"	5	5	5	28	28	28
	12	19.5-20.5	0.770-0.810	20							
	13-14	20.5-21.5	0.810-0.845	21							
	15-16	21.5-22.5	0.845-0.885	22							
	18	22.5-23.5	0.885-0.925	23							
	19-20	23.5-24.5	0.925-0.965	24							
3/4" Gas	13	21.5-22.5	0.845-0.886	22 G			6	6		31	31
	14-15	22.5-23.5	0.886-0.925	23 G							
	16-17	23.5-24.5	0.925-0.965	24 G							
	19-21	24.5-25.5	0.965-1.005	25 G							
	10	24.5-25.5	0.965-1.005	25							
1.1/4"	11-12	25.5-26.5	1.005-1.045	26	1"		7	7		34	34
	13	26.5-27.5	1.045-1.085	27							
	14-15	27.5-28.5	1.085-1.125	28							
	16-18	28.5-29.5	1.125-1.160	29							
	19-22	29.5-30.5	1.160-1.200	30							
	23-24	30.5-31.5	1.200-1.240	31							
	9	25.5-26.5	1.005-1.045	26 G							
1" Gas	10	26.5-27.5	1.045-1.085	27 G			8	8		37	37
	11-12	27.5-28.5	1.085-1.125	28 G							
	13-14	28.5-29.5	1.125-1.160	29 G							
	10-11	31.5-32.5	1.240-1.280	32							
1.1/2"	12-13	32.5-33.5	1.280-1.320	33				9	9	41	41
	14	33.5-34.5	1.320-1.360	34							
	15-17	34.5-35.5	1.360-1.400	35							
	18-20	35.5-36.5	1.400-1.440	36							
	21-24	36.5-37.5	1.440-1.475	37							

**Note :** All models indicated above are for continuous tube pulling. When you are using equipment for stub pulling, please contact us for modifications needed.

# WORKING CONSUMABLES - CONTINUOUS TUBE PULLER

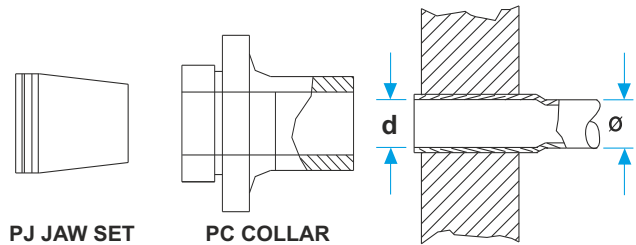
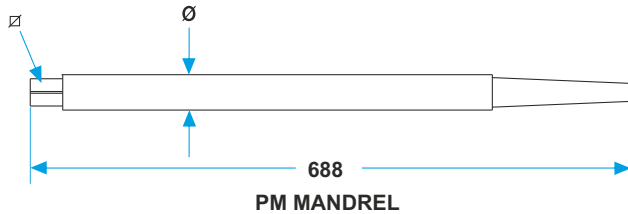

Tube Size		Tube I.D. after Expansion D		Mandrel		Jaw Set			Collar			
		mm	inch	Model	Square Size	Model For HPG-15	Model For HPG-30	Model For HPG-45	Model For HPG-15	Model For HPG-30	Model For HPG-45	
OD / Ø	bwg			PM	∅	PJ 15	PJ 30	PJ 45	PC 15	PC 30	PC 45	
1.1/4" Gas	12	36.5-37.5	1.440-1.475	37G	1"							
	13-14	37.5-38.5	1.475-1.515	38G								
	15-16	38.5-39.5	1.515-1.555	39G			10	10		44	44	
	17-19	39.5-40.5	1.555-1.595	40G								
	20-24	40.5-41.5	1.595-1.635	41G								
1.3/4"	10-11	37.5-38.5	1.475-1.515	38/44								
	12	38.5-39.5	1.515-1.555	39/44								
	13-14	39.5-40.5	1.555-1.595	40/44					11			48
	15-16	40.5-41.5	1.595-1.635	41/44								
	18-19	41.5-42.5	1.635-1.675	42/44								
1.1/2" Gas	11-12	42.5-43.5	1.715-1.755	43G								
	13-14	43.5-44.5	1.755-1.795	44G					12			53
	15-17	44.5-54.5	1.795-1.830	45G								
	18-19	45.5-46.5	1.830-1.870	46G								
2"	10	43.5-44.5	1.830-1.870	44/51								
	11-12	44.5-45.5	1.870-1.910	45/51								
	13	45.5-46.5	1.910-1.950	46/51								
	14-15	46.5-47.5	1.950-1.990	47/51					13			54
	16-18	47.5-48.5	1.870-1.910	48/51								
2.1/4"	19-22	48.5-49.5	1.910-1.950	49/51								
	9-10	49.5-50.5	1.950-1.990	50/57	1.1/2"							
	11	50.5-51.5	1.990-2.030	51/57								
12-13	51.5-52.5	2.030-2.070	52/57									
2" Gas	7	50.5-51.5	1.990-2.030	51G								
	8	51.5-52.5	2.030-2.070	52G								
	9	53.5-53.5	2.070-2.105	53G					14			60
2.1/2"	7	53.5-54.5	2.015-2.145	54/63								
	8	54.5-55.5	2.145-2.185	55/63								
	9	55.5-56.5	2.185-2.225	56/63								
	10	56.5-57.5	2.225-2.265	57/63					15			63
3"	7	66.5-67.5	2.580-2.620	67/76								
	8	67.5-68.5	2.620-2.660	68/76								
	9-10	68.5-69.5	2.660-2.695	69/76								
	11	69.5-70.5	2.695-2.735	70/76				16			66	
								17			80	

**Note :** For Tubes larger than 3" O.D., please contact us for larger size working consumables and larger size tube pulling guns.  
 All models indicated above are for continuous tube pulling. When you are using equipment for stub pulling, please contact us for modifications needed.





# AUTO STUB PULLER

### Features :

- Designed for fast removal of ferrous and non-ferrous tubes from Condensers, Heat Exchangers, and Boilers.
- A rapid stroke allows the removal of 10 tubes a minute with little operator efforts.
- Gripping and pulling done in single operation.
- Compact and lightweight pulling gun, easy to operate inside boiler drum with 24 Volt DC control.
- Auto ejection of tube after removal.
- Remove tubes without any damage to tube sheet.
- Pneumatic version available for hazardous and explosive areas.
- Low setup time and ease of operation.
- Auto Switchover from low-pressure high flow to high-pressure low flow on load and back again when load is released.
- Interchangeable pulling gun with same power pack.
- Significant savings of time & money over conventional methods of stub removal.
- Can pull from 13 mm to 51 mm I.D. tubes.

### OPERATION

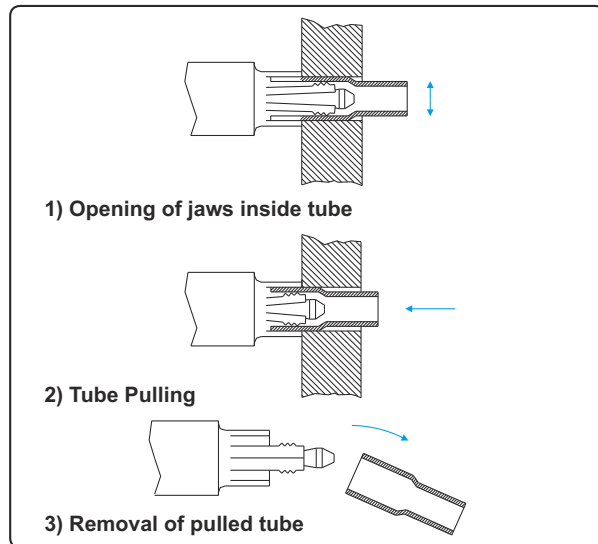

### AUTO STUB PULLER SET

Model	Tube Size ID		Stub Pulling Gun Model	Hydraulic Powerpack Model	Spring Balancer Model To Suspend Gun
	mm	inch			
ASP-1	13 - 31	1/2 - 1.1/4	CTP - 900	PPP-35 / EPP - 15	SWF - 22
ASP-2	31 - 51	1.1/4 - 2	CTP - 1100	PPP-35 / EPP - 15	SWF - 40

### STUB PULLING GUN - SPECIFICATIONS

Model Number	CTP-900	CTP-1100
Capacity / inside dia. of expanded tube (mm)	13 to 31	31 to 51
Maximum stroke (mm)	75	120
Weight (kg)	21	39
Max. Working Pressure (bar)	700	700
Max. Pulling force (ton)	13	31



### HYDRAULIC POWERPACK - SPECIFICATIONS

Model Number	PPP-35	EPP-15
Power	Pneumatic	Electric
Motor H.P	3.5	1.5
Flow rate	4.5 lpm at 0 - 70 bar 1.8 lpm at 70 - 700 bar	3.5 lpm at 0 - 70 bar 0.45 lpm at 70 - 700 bar
Tank capacity (liters)	10	10
Weight including oil (kg)	40	52



**Note :** 5 mtr. long Remote Control and 5 mtr. long Hose set are supplied with Powerpack.

# WORKING CONSUMABLES FOR AUTO STUB PULLER

Part Number	Description
1	Stub Pulling Gun
2	Control Box
3	Tie Rod
4	Compression Spring
5	Guide Washer
6	Jaws
7	Rubber Sleeve
8	Washer
9	Sleeve
10	Support Collar
11	Lock Nut
12	Pulling Collar
13	Spring Balancer

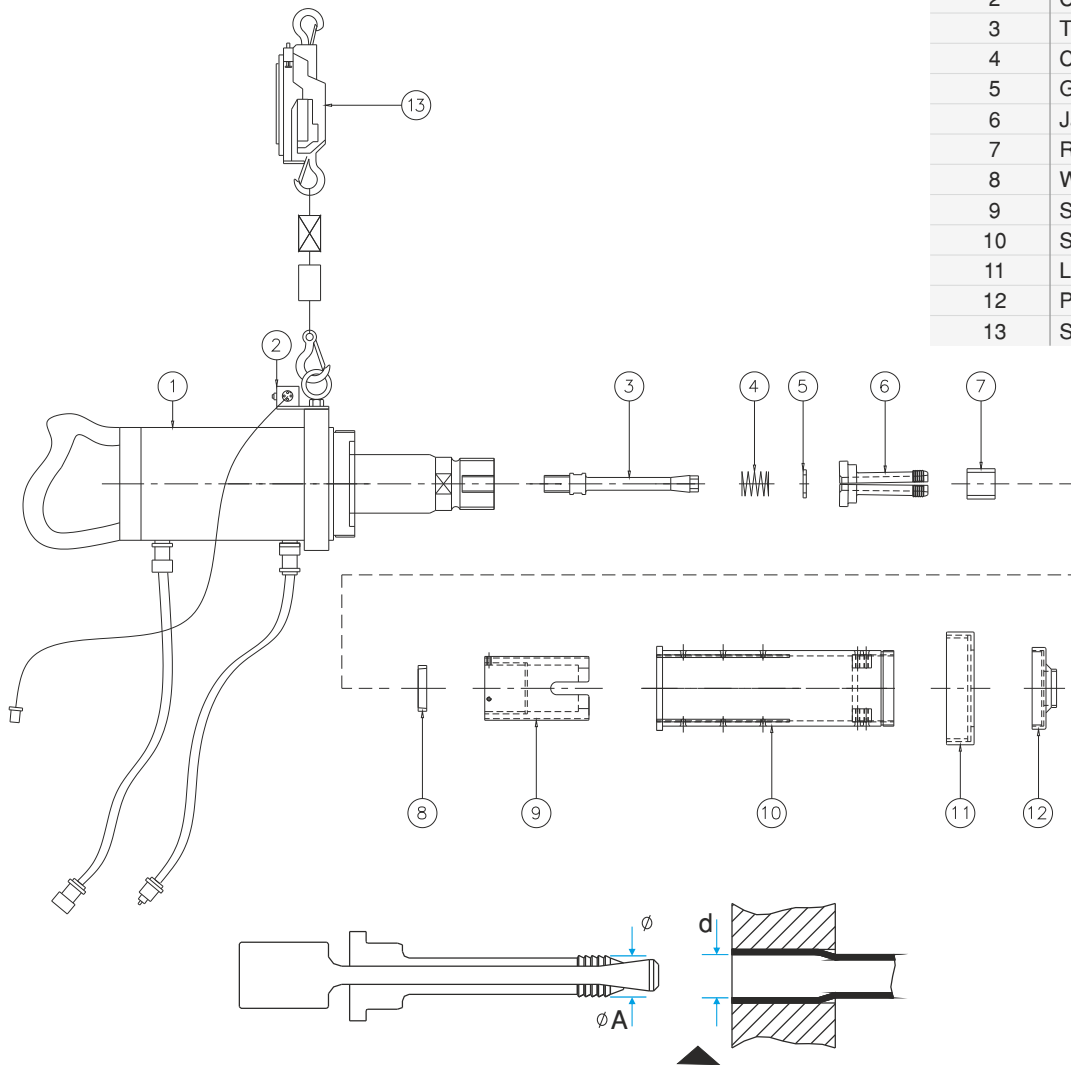

$$\phi A = \phi d - (0.5 \text{ to } 1 \text{ mm})$$

$\phi A$  : diameter of jaws

$\phi d$  : Inside diameter of expanded tube

## JAWS FOR CTP-900





$\phi A$		Model
mm	inch	
12	.472	960/120
13	.512	960/130
14	.551	960/140
15	.591	960/150
16	.630	960/160
17	.669	960/170
18	.709	960/180
19	.748	960/190
20	.787	960/200
21	.827	960/210
22	.866	960/220
23	.906	960/230
24	.945	960/240
25	.984	960/250
26	1.024	960/260
27	1.063	960/270
28	1.102	960/280
29	1.142	960/290
30	1.181	960/300

## JAWS FOR CTP-1100

$\phi A$		Model
mm	inch	
31	1.220	1160/310
32	1.260	1160/320
33	1.299	1160/330
34	1.339	1160/340
35	1.378	1160/350
36	1.417	1160/360
37	1.457	1160/370
38	1.496	1160/380
39	1.535	1160/390
40	1.575	1160/400
41	1.614	1160/410
42	1.654	1160/420
43	1.693	1160/430
44	1.732	1160/440
45	1.772	1160/450
46	1.811	1160/460
47	1.850	1160/470
48	1.890	1160/480
49	1.929	1160/490
50	1.969	1160/500

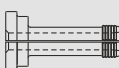
## WORKING CONSUMABLES FOR AUTO STUB PULLER

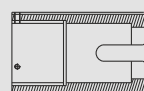
### JAWS - TIE ROD - SUPPORT COLLAR - SLEEVE - PULLING COLLAR FOR CTP TUBE PULLER

						
Gun Model	Jaws Model	Tie Rod Model	Support Collar	Sleeve Model	Pulling Collar Model	Spring Balancer
CTP-900	960/120 to 960/140	970/55	SC-980	S-990	PC-950 Refer chart below	SWF-22
	960/150 to 960/180	970/60				
	960/190 to 960/200	970/80				
	960/210 to 960/240	970/120				
	960/250 to 960/300	970/160				
CTP-1100	1160/310 to 1160/350	1170/220	SC-1180	S-1190	PC-1150 Refer chart below	SWF-40
	1160/360 to 1160/400	1170/270				
	1160/410 to 1160/450	1170/320				
	1160/460 to 1160/500	1170/370				

### COLLARS FOR CTP TUBE PULLERS

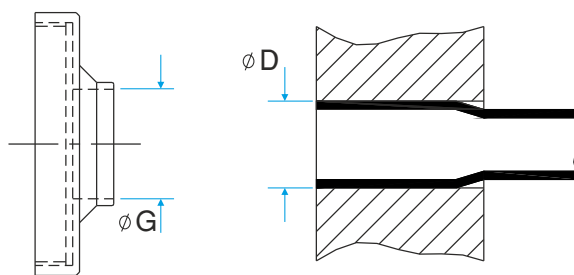

$$\phi G = \phi D + 3 \text{ mm}$$

$\phi A$  : inside diameter of collar

$\phi D$  : outside diameter of tube to be pulled

#### FOR CTP - 900

##### PULLING COLLAR PC-950

OD OF TUBE		INSIDE DIA. OF COLLAR		Model
mm	inch	mm	inch	
15.87	5/8"	19.0	0.748	PC-950/190
19.05	3/4"	22.0	0.866	PC-950/220
22.22	7/8"	25.0	0.984	PC-950/250
25.40	1"	29.0	1.142	PC-950/290
25.40	1.1/8"	32.0	1.260	PC-950/320
31.75	1.1/4"	35.0	1.378	PC-950/350
34.92	1.3/8"	38.0	1.496	PC-950/370

#### FOR CTP - 1100

##### PULLING COLLAR PC-1150

OD OF TUBE		INSIDE DIA. OF COLLAR		Model
mm	inch	mm	inch	
38.10	1.1/2"	41.0	1.614"	PC-1150/410
41.27	1.5/8"	44.0	1.732"	PC-1150/440
44.45	1.3/4"	48.0	1.890"	PC-1150/480
47.62	1.7/8"	51.0	2.001"	PC-1150/510
50.80	2"	54.0	2.126"	PC-1150/540
53.97	2.1/8"	57.0	2.244"	PC-1150/570

# TUBE REMOVAL TOOLS

3/8" - 4"  
O.D.



## TUBE WALL REDUCER

### Features :

- Used to 'thin' the walls of heavy gauge tubes as a step in their removal from tube sheet.
- Suffix model number with tube gauge when ordering. Example for 3/4" O.D. 16G, model number will be WR-750-16.
- Wall reducers available for mm tube sizes also. Please enquire.
- Wall reducers are suited for tube sheets up to 5" thick. Longer reaches are available.



## TUBE DRIFT/KNOCKOUT TOOL

### Features :

- Used with pneumatic chipping hammer to knock out tubes / tube stubs from tube sheet.
- Available in 01 and 06 shanks as standard. 15 (Jumbo) shank available on request.
- Suffix model number with tube gauge and shank when ordering. Example for 3/4" O.D. 16G, 06 shank, model number will be KT-750-16-06.
- Tube Drifts are available for mm tube sizes also. Please enquire.
- Standard reach is 6". Longer reaches are available.



## COLLAPSING TOOL

### Features :

- Used to collapse tube and drive out collapsed tube from tube sheet with a chipping hammer.
- Recommended for use on 16G and thinner tubes.
- Available on 01 and 06 shanks as standard.
- Suffix model number with shank number when ordering. Example for 3/4" O.D. 16G, 06 shank, model number will be CT-750-06.
- Collapsing tools are available for mm tube sizes and larger tube sizes. Please enquire.

Tube O.D. inch	Model Number	MT Shank #
3/8	WR-375	1
1/2	WR-500	2
5/8	WR-625	2
3/4	WR-750	2
7/8	WR-875	2
1	WR-1000	3
1.1/4	WR-1250	3
1.1/2	WR-1500	3
1.3/4	SH-1750	3
2	SH-2000	3
2.1/2	SH-2500	4
2.3/4	SH-2750	4
3	SH-3000	4
3.1/4	SH-3250	4
3.1/2	SH-3500	4
4	SH-4000	4

Tube O.D. inch	Model Number
3/8	KT-375
1/2	KT-500
5/8	KT-625
3/4	KT-750
7/8	KT-875
1	KT-1000
1.1/4	KT-1250
1.1/2	KT-1500
1.3/4	KT-1750
2	KT-2000
2.1/2	KT-2500
2.3/4	KT-2750
3	KT-3000
3.1/4	KT-3250
3.1/2	KT-3500
4	KT-4000

Tube O.D. inch	Model Number
3/8	CT-375
1/2	CT-500
5/8	CT-625
3/4	CT-750
7/8	CT-875
1	CT-1000
1.1/4	CT-1250
1.1/2	CT-1500
1.3/4	CT-1750
2	CT-2000
2.1/2	CT-2500



Chipping Hammer with safety retainer for use with Tube Drifts / Collapsing Tools.

### MODEL CH-1 - SPECIFICATION

Blows/min	Bore	Stroke	Weight
1600	1.1/8" (28.5mm)	3.1/4" (82.5mm)	16lbs (7.0kg)

$\frac{5}{8}$ " -  $1\frac{1}{2}$ "  
O.D.

## PUSH TYPE INTERNAL TUBE CUTTER - ATP SERIES



- POWERMASTER AMERICA "Push Type" Internal Tube Cutter quickly cuts through the walls of ferrous tubes in Condensers and Heat Exchangers as a step in their removal from the tube sheet.
- This sturdy "Push Type" Internal Tube Cutter can be used with a portable Electric or Air Drill Motor.
- "Push Type" Cutter is simple to operate. Merely insert it into the tube, apply power, press inward and the tube can be cut in a few seconds. Releasing of inward pressure automatically retracts the Cutter Bit. This Cutter is equipped with an adjustable collar suitable for reaching into tubes at various depths.
- The replaceable cutting bit can be interchanged in a few seconds. Standard adjustable reach is 4"(101.6mm) and they are available in optional increments of 2"(50.8mm). "A" reach = 6"(152.4mm). "B" reach = 8"(203.2mm). "C" reach = 10"(254.0mm) etc. All Tube Cutters come with a complete set of pilots covering the entire range of tube thicknesses for a particular tube O.D. (ATP-625 tube cutters come with a built in pilot suitable for one tube ID only.)
- All Cutters are available for MM tube sizes also. Please enquire.

Tube O.D.	Tube Gauge (BWG)	Tube Cutter Model No. (Std. Reach)	Spare Cutting Bit Model No.
5/8"	14 - 22	ATP-625	ATP-625-SB
3/4"	14 - 22	ATP-750	ATP-750-SB
7/8"	14 - 22	ATP-875	ATP-875-SB
1"	12 - 22	ATP-1000	ATP-1000-SB
1.1/4"	12 - 22	ATP-1250	ATP-1250-SB
1.1/2"	12 - 22	ATP-1500	ATP-1500-SB

**Note :** When ordering Spare Cutting Bits, please specify whether ordering for Non Ferrous, Ferrous or Stainless Tubes. Cutter Bits for these 3 types of tubes are different. Please refer to operation manual for parts list and detailed features.

## INTERNAL TUBE CUTTER - PR68 SERIES

$\frac{1}{2}$ " -  $4\frac{1}{2}$ "  
O.D.

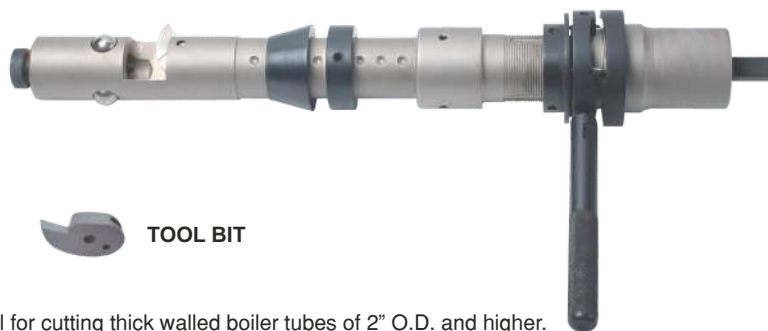

- PR-68 tube cutters are ideal for cutting thick walled boiler tubes of 2" O.D. and higher.
- The Internal Tube Cutter PR-68 is driven via the square in a clockwise direction using either an electric, pneumatic or hydraulic driving machine.
- PR-68 type tube cutters are available in standard reach of 4" (100mm). Additional reaches in increments of 4" are available up to 16" (400mm).

Size	Tool Model Number	Spare Bit Model Number	Tube I.D. Range		Max. Tube O.D.		Body Diameter		Drive Square Male
			mm	inch	mm	inch	mm	inch	
095	0680951	1680951	10 - 12	.394 - .472	15	.591	9.5	.374	1/2"
105	0681051		11 - 13	.433 - .512	18	.709	10.5	.413	
115	0681151	1681151	12 - 14	.472 - .551	19	.748	11.5	.453	
125	0681251	1681251	13 - 15	.519 - .591	20	.787	12.5	.492	
135	0681351		14 - 17	.551 - .669	23	.906	13.5	.531	
155	0681551		16 - 19	.630 - .748	25	.984	15.5	.610	
175	0681751	1681751	18 - 21	.709 - .827	27	1.063	17.5	.689	
195	0681951	1681951	20 - 25	.787 - .984	34	1.339	19.5	.768	
245	0682451	1682451	25 - 30	.984 - 1.181	38	1.496	24.5	.965	
290	0682901	1682901	30 - 35	1.181 - 1.378	43	1.693	29	1.142	
330	0683301		35 - 40	1.378 - 1.575	48	1.890	33	1.299	
380	0683801		40 - 50	1.575 - 1.969	58	2.126	38	1.496	
480	0684801	1684801	50 - 60	1.969 - 2.362	68	2.677	48	1.890	3/4"
530	0685301		55 - 65	2.165 - 2.559	73	2.874	53	2.087	
630	0686301		65 - 75	2.559 - 2.953	83	3.268	63	2.480	
730	0687301		75 - 85	2.953 - 3.346	93	3.661	73	2.874	
830	0688301		1687301	85 - 95	3.346 - 3.740	103	4.055	83	
930	0689301	95 - 105	3.740 - 4.134	113	4.449	93	3.661		

**Note :** Refer to operation manual for detailed features and parts list.

# ONE REVOLUTION INTERNAL TUBE CUTTER - OTC SERIES

5/8" - 2 1/2"  
O.D.



TOOL BIT

- Powermaster America "One Revolution" Internal Tube Cutter pierces and cuts off non-ferrous and thin walled ferrous tubes in one revolution.
- This "One Revolution" Internal Tube Cutter is designed for hand operation using a ratchet handle.
- The Cutter Tool Bit operates on an eccentric principle. The Tube Cutter is entered in the tube with the Tool Bit in closed position, ratchet is applied and turned in clockwise direction. The Tool Bit contacts the tube during the One Revolution and pierces the tube wall and as turning is continued the Tool Bit shears through the tube along its circumference. This Cutter is fitted with an adjustable collar enabling it to reach into tubes at various distances and they are available in optional increments of 2"(50.8mm). Standard adjustable reach is 6"(152.4mm). "A" reach = 8"(203.2). "B" reach = 10"(254.0mm). "C" reach = 12"(304.8mm) etc.
- All Cutters are available for MM tube sizes also.

Tube O.D.		Tube Gauge (BWG)	Tube I.D.		Cutter Model No.	Spare Bit Model No.
mm	inch		mm	inch		
15.87	5/8"	14	11.4 - 11.9	.450 - .470	OTC-625-14	OTC-625-SB
		15 - 16	12.0 - 12.9	.472 - .510	OTC-625-16	
		17 - 18	12.7 - 13.5	.500 - .531	OTC-625-18	
		19 - 20	13.5 - 14.2	.531 - .560	OTC-625-20	
		22	14.0 - 14.7	.550 - .580	OTC-625-22	
19.05	3/4	14 - 15	14.7 - 15.5	.580 - .610	OTC-750-14	OTC-750-SB
		16	15.2 - 16.0	.600 - .630	OTC-750-16	
		17 - 18	15.9 - 16.5	.625 - .650	OTC-750-18	
		19 - 20	16.7 - 17.5	.660 - .690	OTC-750-20	
22.22	7/8	14 - 15	17.8 - 18.5	.700 - .730	OTC-875-14	OTC-875-SB
		16 - 17	18.8 - 19.5	.740 - .770	OTC-875-16	
		18	19.3 - 20.0	.760 - .790	OTC-875-18	
		19 - 20	19.8 - 20.6	.780 - .810	OTC-875-20	
25.40	1"	14	20.8 - 21.6	.820 - .850	OTC-1000-14	OTC-1000-SB
		15	21.3 - 22.1	.840 - .870	OTC-1000-15	
		16 - 17	22.8 - 22.6	.860 - .890	OTC-1000-16	
		18 - 20	22.6 - 23.1	.890 - .910	OTC-1000-18	
		22	23.9 - 24.6	.940 - .970	OTC-1000-22	
31.75	1.1/4	12	25.9 - 26.7	1.020 - 1.050	OTC-1250-12	OTC-1250-SB
		13 - 14	26.7 - 27.4	1.050 - 1.080	OTC-1250-14	
		15 - 16	27.9 - 28.7	1.100 - 1.130	OTC-1250-16	
		17 - 19	28.7 - 29.6	1.130 - 1.160	OTC-1250-18	
38.10	1.1/2	12 - 13	32.5 - 33.3	1.280 - 1.310	OTC-1500-12	OTC-1500-SB
		14 - 15	33.8 - 34.5	1.330 - 1.360	OTC-1500-14	
		16 - 17	34.5 - 35.3	1.360 - 1.390	OTC-1500-16	
		18 - 19	35.3 - 36.1	1.390 - 1.420	OTC-1500-18	
50.80	2	12 - 13	45.0 - 46.0	1.770 - 1.810	OTC-2000-12	OTC-2000-SB
		14 - 15	46.2 - 47.2	1.820 - 1.860	OTC-2000-14	
		16 - 17	47.2 - 48.2	1.860 - 1.900	OTC-2000-16	
		18 - 19	48.0 - 49.0	1.890 - 1.930	OTC-2000-18	
63.50	2.1/2	12 - 13	57.6 - 58.6	2.270 - 2.310	OTC-2500-12	OTC-2500-SB
		14 - 15	58.9 - 60.0	2.320 - 2.360	OTC-2500-14	
		16 - 17	60.0 - 61.0	2.360 - 2.400	OTC-2500-16	
		18 - 19	60.7 - 61.7	2.390 - 2.430	OTC-2500-18	



**MANUAL TUBE PULLER**



*Features :*

- No power needed: Manual insertion and removal of tube with a hand wrench. Ideal for field service applications.
- Simple Design : Only two major parts reduce inventory.
- Ease of use : Hex at back of spear allows tightening without disassembly of thrust mechanism.
- Range of Sizes : A wide range of sizes allows use on popular tube size. Clarity of markings: Both spear and thrust collar are clearly marked for fast relating tool to job.

Tube Size							Tube Puller Model Number	Spare Spear Model Number
O.D.		BWG	Wall Thickness		I.D.			
mm	inch		mm	inch	mm	inch		
6.35	1/4	18	1.24	.049	3.86	.152	MTP-25-18	MPS-25-18
9.52	3/8	16	1.65	.065	6.22	.245	MTP-38-16	MPS-38-16
9.52	3/8	18	1.24	.049	7.04	.277	MTP-38-18	MPS-38-18
9.52	3/8	20	0.88	.035	7.75	.305	MTP-38-20	MPS-38-20
12.70	1/2	14	2.11	.083	8.48	.334	MTP-50-14	MPS-50-14
12.70	1/2	16	1.65	.065	9.40	.370	MTP-50-16	MPS-50-16
12.70	1/2	18	1.24	.049	10.21	.402	MTP-50-18	MPS-50-18
12.70	1/2	20	0.88	.035	10.92	.430	MTP-50-20	MPS-50-20
15.88	5/8	14	2.10	.083	11.66	.459	MTP-63-14	MPS-63-14
15.88	5/8	16	1.65	.065	12.57	.495	MTP-63-16	MPS-63-16
15.88	5/8	18	1.24	.049	13.39	.527	MTP-63-18	MPS-63-18
15.88	5/8	20	0.88	.035	14.10	.555	MTP-63-20	MPS-63-20
19.05	3/4	14	2.10	.083	14.86	.585	MTP-75-14	MPS-75-14
19.05	3/4	16	1.65	.065	15.75	.620	MTP-75-16	MPS-75-16
19.05	3/4	18	1.24	.049	16.56	.652	MTP-75-18	MPS-75-18
19.05	3/4	20	0.88	.035	17.27	.680	MTP-75-20	MPS-75-20
22.22	7/8	14	2.10	.083	18.01	.709	MTP-87-14	MPS-87-14
22.22	7/8	16	1.65	.065	18.92	.745	MTP-87-16	MPS-87-16
22.22	7/8	18	1.24	.049	19.74	.777	MTP-87-18	MPS-87-18
22.22	7/8	20	0.88	.035	20.45	.805	MTP-87-20	MPS-87-20
25.40	1	14	2.10	.083	21.18	.834	MTP-100-14	MPS-100-14
25.40	1	16	1.65	.065	22.10	.870	MTP-100-16	MPS-100-16
25.40	1	18	1.24	.049	22.91	.902	MTP-100-18	MPS-100-18
25.40	1	20	0.88	.035	23.62	.930	MTP-100-20	MPS-100-20

**Note :** For larger/other sizes, please enquire.

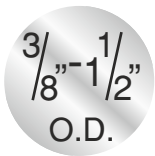

**TUBE PLUGS**



**ONE PIECE**



**TWO PIECE**

- Tube plugs are designed for sealing off leaking or damaged tubes in heat exchangers, condensers, boilers etc. It ensures a uniform joint without damaging the tube sheet.

Tube O.D.		One Piece Tube Plug Model No.	Two Piece Tube Plug Model No.
mm	inch		
9.53	3/8	PLG-375-1	-
12.70	1/2	PLG-500-1	PLG-500-2
15.87	5/8	PLG-625-1	PLG-625-2
19.05	3/4	PLG-750-1	PLG-750-2
22.22	7/8	PLG-875-1	PLG-875-2
25.40	1	PLG-1000-1	PLG-1000-2
31.75	1.1/4	PLG-1250-1	PLG-1250-2
38.10	1.1/2	PLG-1500-1	PLG-1500-2

**Note :** Tube plugs are available in a variety of materials like carbon steel, brass, stainless steel, fibre etc. Specify material needed when ordering.

# 'PINE JENNY' STYLE TUBE PULLING ACCESSORIES

## 'PINE JENNY' TUBE SPEARS



3/8" - 1" TUBE SPEAR

Model Number	Tube OD inch	BWG
S-0916	3/8	16-17
S-0918	3/8	18-19
S-0920	3/8	20-21
S-0922	3/8	22-24
S-1212	5/8	12-13
S-1214	5/8	14-15
S-1216	5/8	16-17
S-1218	5/8	18-19
S-1220	5/8	20-21
S-1911	3/4	11-13
S-1914	3/4	14-15
S-1916	3/4	16-17
S-1918	3/4	18-19
S-1920	3/4	20-21
S-2212	7/8	12-13
S-2214	7/8	14-15
S-2216	7/8	16-17
S-2218	7/8	18-19
S-2220	7/8	20-21



1.1/4" - 3" TUBE SPEAR

Model Number	Tube OD inch	BWG
S-2509	1	9
S-2510	1	10-11
S-2512	1	12-13
S-2514	1	14-15
S-2516	1	16-17
S-2518	1	18-19
S-2520	1	20-21
S-3112	1-1/4	12-13
S-3114	1-1/4	14-15
S-3116	1-1/4	16-17
S-3318	1-1/4	18-19
S-3120	1-1/4	20-21
S-3814	1-1/2	14-16
S-3817	1-1/2	17-20
S-4414	1-3/4	14-18
S-5014	2	14-18
S-5714	2-1/2	14-18
S-7610	3	10-14

**Note :** For other sizes of 'Pine Jenny' spears. Please enquire.



3055-3 SINGLE PULL ADAPTOR



3055-6 DOUBLE PULL ADAPTOR



3055-5 MALE X MALE EXTENSION



3055-10 MALE X FEMALE EXTENSION



3055-4 HORSE SHOE LOCK



EXTENSION CHAIRS

Model	Tube O.D.
80-3055-7	1.1/4" - 1.1/2"
80-36307	1.3/4"
80-36308	2" - 2.1/4"
80-36309	2.1/2"
80-36310	2.3/4" - 3"

**Note :** All the above items are compatible for use with Tube Pulling Systems of Airetool, Wilson, Elliot and other manufacturers of "Pine Jenny" style systems.

Extension chair is sized to allow tube being pulled to enter I.D. of chair. Spears, Adaptors, Male x Male Extension, Horse Shoe Lock and Extension Chair are needed for sizes 1.1/4" O.D. and larger. Male x Female Extensions are used for longer reach. Consult us for sizes not listed here.



# TUBE BUNDLE EXTRACTORS

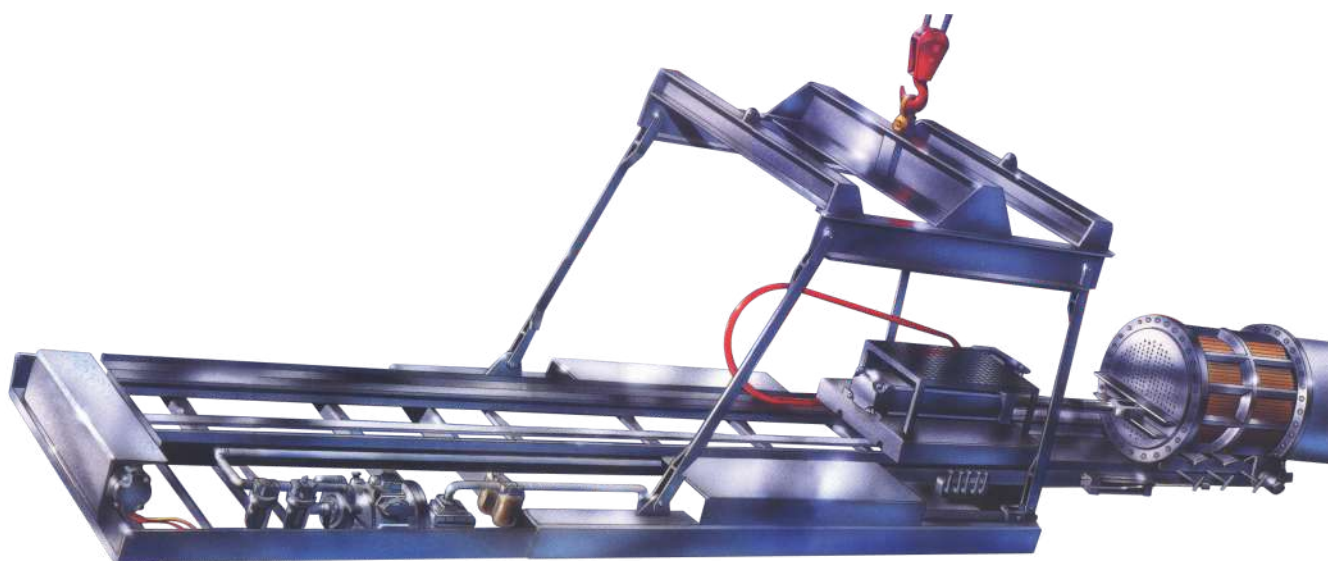

Tube Bundle Extractor specifically designed to remove the tube bundle from the tube sheet without damage to shell of heat exchangers.

### Features :

- 1) Units are designed to be self supporting using either a diesel engine W/ Spark arrestor, or an 18 HP piston type air motor.
- 2) Units can be manufactured with optional remote control so that operator can stand away at safe distance during initial break out of tube bundle.
- 3) Bundle extraction time is 15 - 20 minutes depending upon job situation & operators experience.

- Please enquire for more details.

### APPROXIMATE WEIGHTS & MEASURES FOR TUBE BUNDLE EXTRACTOR

Model Number	Bundle Length feet	Bundle* Dia. inch	Extractor Dimensions long x wide x high feet	Weight	
				Kgs	Lbs
504	20	66	27-2 x 6-0 x 3-0 *	6,590.0	14,500
504-S-24	24	66	30-8 x 6-0 x 3-0*	7,272.0	16,000
504-S-28	28	66	34-2 x 6-0 x 3-0*	7,772.0	17,100
504-S-32	32	66	37-8 x 6-0 x 3-0*	10,909.0	24,000

\* Optional bowed tension arms: for bundle tube sheet diameters up to 84" force applied with main cylinder; 113.100 lbs. Standard (189,000 lbs Optional)

\* (8ft High in operational position)

**POWERMASTER AMERICA LLC.**

26, Russell Park Road, Syosset, New York 11791.

Phone : +1 516.503.5294

Website: [www.powermasteramerica.com](http://www.powermasteramerica.com) Email: [sales@powermasteramerica.com](mailto:sales@powermasteramerica.com)